

~~RESTRICTED~~

DECLASSIFIED

R. E. BOONE

ORDNANCE PAMPHLET 1178

DEMOLITION MATERIAL



LIBRARY COPY

*Historical only per
Index of OP's (OP O)*

RECEIVED

RESTRICTED

ORDNANCE PAMPHLET 1178

DEMOLITION MATERIAL



8 DECEMBER 1944

LIBRARY COPY

**This publication is RESTRICTED and must be handled in accordance
with Article 76, United States Navy Regulations, 1920.**

NAVY DEPARTMENT
BUREAU OF ORDNANCE
WASHINGTON, D. C.

8 December 1944

RESTRICTED
ORDNANCE PAMPHLET 1178
DEMOLITION MATERIAL

1. Ordnance Pamphlet 1178 contains information on the use and construction of demolition material of Navy and Army design supplied to Naval Activities.
2. This publication is intended to serve as a general reference for identification, procurement, and use of demolition material by trained and authorized personnel.
3. This pamphlet does not supersede any existing publication.
4. This publication is RESTRICTED and shall be safeguarded in accordance with the security provisions of U. S. Navy Regulations, 1920, Articles 75 $\frac{1}{2}$ and 76.

G. F. HUSSEY, JR.
Rear Admiral, U. S. Navy
Chief of the Bureau of Ordnance

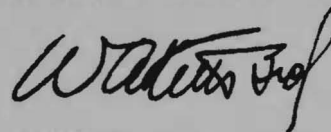

Acting.

CONTENTS

INTRODUCTION

	Page
Purpose of Pamphlet	5
Item Information	6
Appendices	7
Ordering	7

Chapter One—INITIATORS

	Section
Caps and Primers	1
Burning-Type Fuse	2
Firing Devices, Instantaneous Electrical	3
Firing Devices, Instantaneous Mechanical	4
Firing Devices, Delay Electrical	5
Firing Devices, Delay Mechanical	6
Cord, Detonating	7

Chapter Two—BOOSTERS AND FUZES

	Section
Demolition Fuzes	1
Demolition Boosters	2

Chapter Three—CHARGES AND ASSEMBLIES

Hand Placed Point Charges	1
Large Point Charges and Their Assemblies	2
Line Charges and Their Assemblies	3
Cavity Charges	4
Antitank Mines	5
Antipersonnel Mines	6
Antiboat Mines	7
Incendiary Charges	8
Destructors, Special Charges, and Their Assemblies	9

Chapter Four—ACCESSORY EQUIPMENT

Firing Wire	1
Special Equipment	2
Containers	3

- Appendix I—UNIT PACKAGE INDEX**
- Appendix II—CHARACTERISTICS CHART**
- Appendix III—STANDARDS**
- Appendix IV—PUBLICATIONS INDEX**
- Appendix V—ALPHABETICAL INDEX**

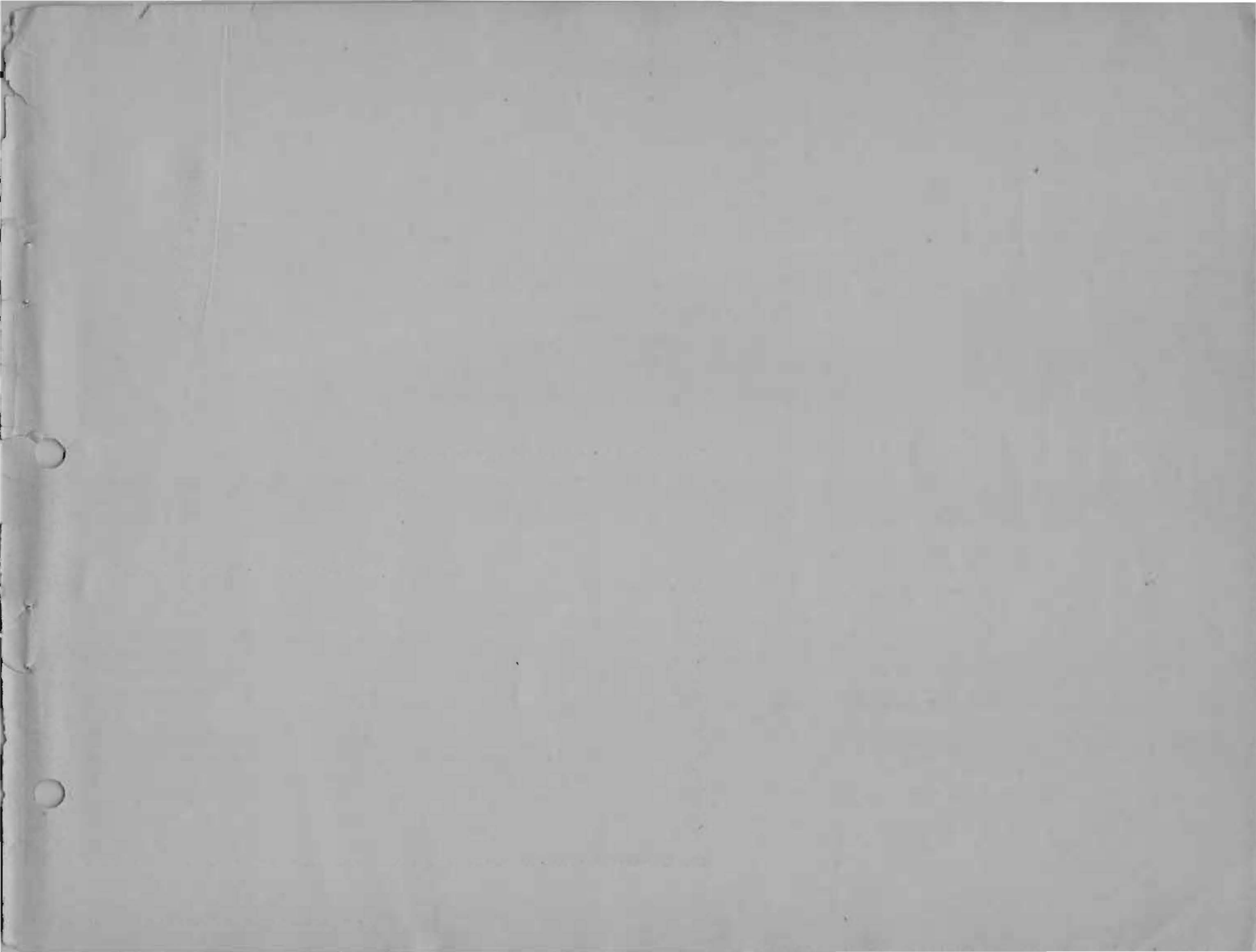

INTRODUCTION

PURPOSE

This publication has been prepared for a number of purposes that are listed and discussed in the headings immediately below.

RECOGNITION ASSISTANCE

One purpose of this pamphlet is to assist in the identification and recognition of demolition material on hand. Issuing agencies and using forces should be informed that descriptions in the pamphlets distinguish only demolition material that would be issued to the United States Naval and Marine Corps forces. If it is possible that material has been obtained from foreign sources, someone familiar with the item desired should establish its identity. This is especially true of burning type fuse or detonating cord, but applies to other classes of items as well. Before using any of these items PERSONNEL SHOULD BE ASSURED (BY TESTS IF NECESSARY) THAT THE ITEM POSSESSES ITS NORMAL CHARACTERISTICS.

PUBLICITY FOR AVAILABLE ITEMS

Another purpose of this pamphlet is to list demolition material available for the use of authorized activities and forces, together with information about ordering. All demolition material of either Navy or Army origin available for such issue, the nature of which can be revealed in a restricted publication, has been described.

CLARIFICATION OF TERMS

Still another purpose of the pamphlet is to secure greater clarity in communications involving demolition items. Suggestions and reports about items are often valueless until additional information is obtained to know exactly what items are referred to. In ordering, not only must the official designations be used but the unit of quantity must be known by both those requesting and those being requested. For example, in the case of Block, Demolition, Chain, M1 the informal expression "1,000 tetrytol charges" might mean 1,000 of the tetrytol blocks themselves, 1,000 of the chains, or 1,000 of the haversacks each containing one chain. By referring to "Tetrytol Pack or Chain" in the alphabetical index or by leafing through the illustrated item pages (11.01 to 49.99) to the item page for Blocks, Demolition Chain, M1

(31.03), the person drafting the communication will be supplied with the necessary information. He can get this by consulting both the item page and the appropriate part of the Unit Package Index (both bearing the same index number). In correspondence a discussion of a demolition item should clearly include or refer to the official designation for that item.

COLLECTION OF GENERAL INFORMATION

Another purpose of this pamphlet is to provide a collection of general information about each demolition item that need not be excluded for reasons of classification. This information includes the general field of usefulness, method of functioning including cause and effect, description, a statement (if applicable) pointing out that certain apparatus mentioned is not included in that particular item but is ordered separately, relationship to standard fittings, and references to other literature concerning the item.

REFERENCES TO OTHER DEMOLITION LITERATURE

Another important purpose of this pamphlet is to set forth for those concerned information about other literature dealing with demolition items in general and with the specific items listed. It is not the purpose of this pamphlet to constitute a training manual or replace the instructional literature for each item. PERSONNEL USING THESE ITEMS MUST BE TRAINED IN CORRECT DEMOLITION TECHNIQUES AND MUST BE FAMILIAR WITH THE ITEM THROUGH INSTRUCTION OR LITERATURE OTHER THAN THIS PAMPHLET. A partial statement of safety precautions is dangerous unless treated as a reminder for trained personnel rather than as directions to those untrained in demolitions or unfamiliar with the item. Statements on safety precautions in this pamphlet only partially cover their field and none are made concerning many of the items listed. Some statements on safety precautions have been included because of the need for giving them a wide circulation.

CLASSES OF ADDRESSEES

This pamphlet was prepared having a number of activities and forces or parts of forces in mind, which are listed below.

- a. Naval combat demolition schools, units, and teams

INTRODUCTION

- b. Bomb disposal schools and units, mine disposal schools and units, and mobile investigation schools and units
- c. Ammunition depots and mine depots
- d. Certain Marine Corps schools and units concerned with demolitions
- e. Ammunition ships
- f. Mine sweepers
- g. Construction battalions
- h. Salvage units
- i. Gunner's mate schools
- j. Hydrographic ships
- k. Certain units of higher classification
- l. Ordnance schools

FORM

This pamphlet has been prepared so that it may be folded across the page for convenience in handling. For convenience of reference, the various demolition items described in this pamphlet have been grouped according to Chapters and Sections and each item assigned its own index number. The basis used in grouping items is explained at the heading of each chapter. The first two digits of the index number consists of the chapter number and the section number, in that order. At the top of each page is printed a four-digit index number or numbers which show the items printed on that page. The first number is the number of the chapter, and the second number is that of the section in that chapter. The numbers after the decimal point indicate the item in that section. For instance: "Block, Demolition, M3--31.05" would be the fifth item in the first section of the third chapter.

MAINTENANCE OF PAMPHLET

Supplementary pages will be issued as new equipment becomes available, or as more highly classified equipment comes into general use and its classification is reduced. The prompt insertion of newly issued pages, to continually maintain up to date information in this pamphlet, will materially contribute to the expeditious procurement and handling of the most effective demolition material.

ITEM INFORMATION

Information on each individual item or assembly of items supplied as an independent unit, which is contained on the page or pages describing that item, has been divided into the following headings:

OFFICIAL DESIGNATION

The bold type at the top of the page shows the official name for the item which is to be used in ordering or whenever the item is referred to in correspondence.

USE

Here general applications and operating characteristics of the item are briefly discussed.

DESCRIPTION

Under this heading the method of operation and the construction of the equipment and its component parts are briefly described.

CONNECTING ITEMS

Under this heading is listed some of the equipment to which the principal item on the item page can be connected. Often only one or a few of the connecting items mentioned would be connected to the principal item in any one installation. No attempt has been made to list all possible uses or installations of the principal item. Rather, the equipment that will connect with or fit the principal item has been listed. For a better understanding of standard connections used in demolition work the appendix on Standards (Appendix III) should be consulted.

REFERENCES

The page or paragraph numbers, and the publication number, of any military publication listed in Appendix IV which contains supplementary information on the specific item, are referenced here.

APPENDICES

Appendix I—UNIT PACKAGE INDEX

All the demolition materials in the catalog are listed here in a tabular form which gives information necessary for procurement, handling and stowage.

Appendix II—CHARACTERISTICS CHART

The functions performed and the end effect of each demolition item except accessory equipment is charted for "at a glance" reference.

Appendix III—STANDARDS

These descriptions include dimensions, tolerances, and other pertinent information concerning the fitting together of demolition material designed to be used together in a variety of combinations.

Appendix IV—PUBLICATIONS INDEX

All military publications, both Navy and Army, generally available to field activities, are listed with brief descriptions of their contents.

Appendix V—ALPHABETICAL INDEX

This listing in alphabetical order of both the official nomenclature and common names of demolition material gives the catalog index number, which information will be found on that material.

ORDERING

SHIPS

Requests for demolition material from ships to fill established allowances, and for replacement of expended demolition material shall follow the procedure outlined in NAVORD OCL A14-44. Where Allowance Lists are provided, the original issue of demolition material may be obtained by all Naval Vessels direct from Naval Ammunition Depots or Mine Depots at any time without reference to the Bureau of Commandant of the District concerned. Requests shall be in letter form. Requests for demolition material "in excess," or not covered by the Bureau of Ordnance Allowance Lists shall be addressed to the

Bureau of Ordnance and should include all information described in "Ordering Information Required".

STATIONS AND SHORE ACTIVITIES

Requests for demolition material for stations and shore activities other than Marine Corps stations and activities shall be in letter form addressed to the Bureau of Ordnance. However, movements of demolition material by shore activities in order to maintain stock levels established by the Bureau of Ordnance, and for which blanket shipment orders have been issued, shall be in letter form requests to the supplying activity without reference to the Bureau of Ordnance.

MARINE CORPS UNITS

Request for demolition material from U. S. Marine Corps units should be directed to the Quartermaster (Engineers Section), U. S. Marine Corps Headquarters, who will forward them to the Bureau of Ordnance.

UNDERWATER DEMOLITION TEAMS

Material for Underwater Demolition Teams is to be requested from The Chief of Naval Operations.

ORDERING INFORMATION REQUIRED

To assure the most expeditious handling of requisitions, descriptions of the items required should be as complete and definite as possible. Appendix I, Unit Package Index, provides all of the procurement and stowage information normally required for the items shown in this pamphlet. The following minimum information is required for proper handling of requisitions:

- a. The official designation as shown in the Unit Package Index and in bold type at the head of each item description in the pamphlet.
- b. The correct Mark and Mod number. In all cases where no modification exists, the designation Mod 0 should be used. The Navy code number shown in the Unit Package Index in this pamphlet should normally be included for added certainty. However, this should be omitted in dispatches where communications traffic is heavy.

INTRODUCTION

INFORMATION WHEN ORDERING NEW AND REDESIGNED ITEMS

On new and redesigned items, distribution will be critical and will be made under the guidance of the Chief of Naval Operations. Requests through established logistic channels on new or redesigned items should accordingly indicate the following information:

- a. Estimated quantity required for immediate important operational purposes.
- b. Estimated quantity anticipated for expenditure or installation per month.
- c. Stock level considered desirable to cover contingencies.

INFORMATION WHEN ORDERING NEW ITEMS FOR SHIPS

New kinds of demolition material for a class of ships may involve new risks and thereby affect the fighting characteristics of the ship. Hence, policy determinations have sometimes barred certain items from a particular class of ships. It is desirable, when ordering new items for storage and use aboard ship, to outline the following information:

- a. Use to which the item would be put
- b. Part or parts of ship where it would be used, if known

c. Part or parts of ships where it would be stowed or kept in readiness

d. Condition of stowage or readiness. Where the item page contains a reference to this page, the use of that item aboard ship is likely to be questioned.

INFORMATION WHEN ORDERING ITEMS OF LIMITED STOCK

Some items are stocked only in limited quantities because the ordinary requirements are best met by other items. Where this page number is referenced on the item page, the item is of limited stock. The use to which the item would be put and its advantage in such use would be stated when ordering.

CERTAIN EXPLOSIVES NOT ISSUED FOR MILITARY PURPOSES

Dynamites are not issued by the Bureau of Ordnance for military purposes because of their sensitivity to bullet impact and because of their relatively rapid deterioration which requires special surveillance and inventory control.

Chapter One describes the flash or detonation items which are supplied independently and used interchangeably in a number of field assemblies for producing a detonation of demolition charges principally by means of blasting caps or electric detonators. Interchangeable Detonating Assemblies (Appendix III) illustrates some field assemblies. Chapter One is divided into sections, primarily according to the method of functioning, as follows:

Section 1—CAPS AND PRIMERS

The catch words "Caps and Primers" actually represent the simplest detonation-starting and flash-starting items that can be separately procured for installation with other demolition materials. This section excludes equipment having its own firing control (firing devices) and equipment having its own booster (demolition fuzes, boosters, and some charges).

Section 2—BURNING-TYPE FUSE

Burning-type fuse provides flexible lengths of material designed to be lit at one end and thereafter burn from the lighted end to the other end at a fairly uniform rate.

**Section 3—FIRING DEVICES,
INSTANTANEOUS ELECTRICAL**

These devices supply, at the moment they are actuated, an electric current suitable for causing initiation of electric blasting caps or electric detonators.

**Section 4—FIRING DEVICES,
INSTANTANEOUS MECHANICAL**

These devices, which are designed to be components of Interchangeable Detonating Assemblies (Appendix III), provide a flash at the same instant they are actuated. This flash will initiate a standard blasting cap that has been crimped on to the Coupling Base or initiate an integral detonator.

**Section 5—FIRING DEVICES,
DELAY ELECTRICAL**

These devices provide at a certain time after the device is actuated, an electric current suitable for causing initiation of electric blasting caps or electric detonators.

**Section 6—FIRING DEVICES,
DELAY MECHANICAL**

These devices which are designed to be components of interchangeable Detonating Assemblies (Appendix III) provide a flash or a detonation at a certain time after the device is actuated. This flash will initiate a standard blasting cap that has been crimped onto the Coupling Base or initiate an integral detonator.

Section 7—CORD, DETONATING

Cord, detonating provides flexible lengths of material designed to be detonated from some portion of its length; thus causing the remainder of the attached detonating cord, or properly attached demolition charges, to detonate. (The detonating cord of U. S. manufacture is often known by its proprietary name of "Primacord").

Identification of Blasting Caps

SPECIAL NONELECTRIC BLASTING CAPS (11.01) AND SPECIAL ELECTRIC BLASTING CAPS (11.02)

These are the only blasting caps now issued by the Bureau of Ordnance to Naval activities for combat use with the exception of one No. 8 commercial nonelectric blasting cap issued as a component of Outfit, Demolition Mark 104 Mod. 0 or Mod. 1 (39.01). These Special Blasting Caps (11.01, 11.02) are the only caps that will positively detonate all present military explosives. Boxes containing these caps are marked "Will Detonate Composition C."

Special Electric Blasting Caps manufactured by different companies or of different grades or types should never be used in the same circuit; and the three different makes supplied may be distinguished between themselves by the shape, color, and type of safety shunt as follows:

ATLAS

Red lacquered shell, shaped as shown with a square lead clip safety shunt on bared ends of leg wires.

DUPONT

Blue lacquered shell, shaped as shown with metal foil safety shunt wrapped around bare ends of leg wires.

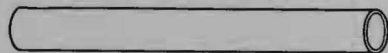

HERCULES

Clear lacquered copper shell, with a concave end as shown, eyelet or ring safety shunt on bared ends of leg wires.

Special Nonelectric Blasting Caps are the size and shape shown above. All makes have clear lacquered copper shells and can be used interchangeably; such as, using nonelectric caps of different manufacture in the same installation.

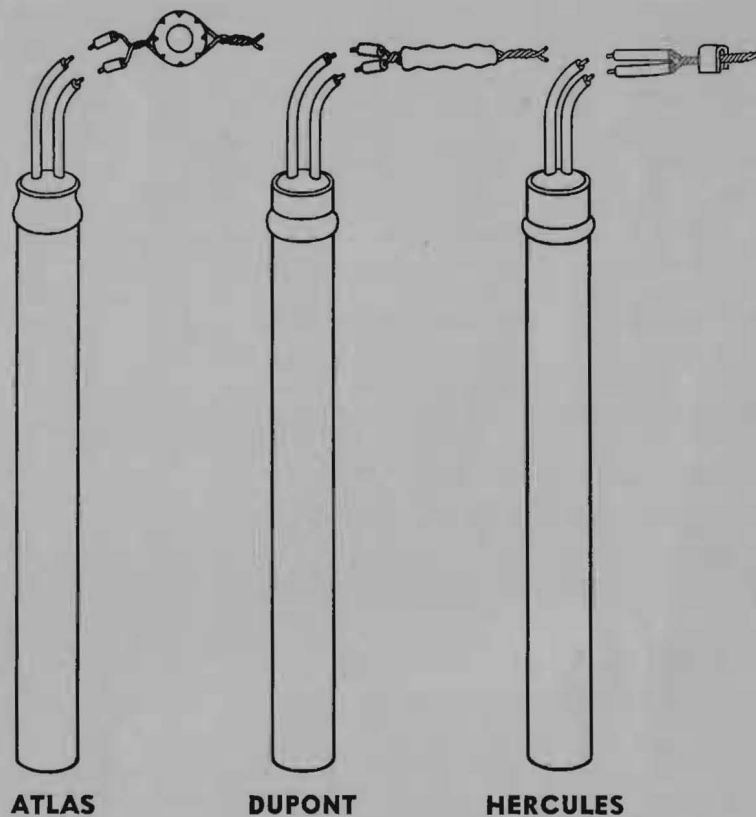

Actual Size

**"TETRYL ELECTRIC" AND "TETRYL NONELECTRIC"
BLASTING CAPS**

These blasting caps (Army Specification 50-78-4) are no longer issued by the Bureau of Ordnance to Naval activities for combat use, but may be encountered in the field. They will not detonate Composition C (31.05); they will not detonate other demolition charges under adverse conditions as reliably as the Special blasting caps (11.01 and 11.02). Therefore, the tetryl electric and tetryl nonelectric blasting caps should be restricted to use in training.

"Tetryl Electric" Blasting Caps manufactured by different companies should never be used in the same circuit; and the three different makes formerly supplied may be distinguished between themselves by the shape, color and type of safety shunt exactly as the Special Nonelectric and Special Blasting Caps are distinguished. "Tetryl Nonelectric" Blasting Caps have the exact appearance of the "Special Nonelectric" Blasting Caps. All makes of nonelectric blasting caps may be used without regard to manufacture.

The only markings to distinguish Special Blasting Caps from "Tetryl" Blasting Caps are found on the box. All Special Blasting Caps are packed in containers marked "Will Detonate Composition C."

NO. 8 COMMERCIAL BLASTING CAPS

These caps are not issued by the Bureau of Ordnance to Naval Activities for combat use with the exception of one No. 8 Commercial Nonelectric Blasting Cap issued as a component of **Outfit, Demolition, Mark 104 Mod. 0 or Mod. 1 (39.01)**. However, No. 8 Commercial Blasting Caps may be encountered in the field. They will detonate detonating cord (17.01, 17.02, 17.03) when properly attached but not as dependably under adverse conditions as the Special Blasting Caps (11.01 and 11.02). They are designated for use with the gas identification set used in chemical warfare training (not elsewhere referred to in this publication).

No. 8 Commercial Electric Blasting Caps manufactured by different companies should never be used in the same circuit; and the three different makes supplied may be distinguished by the shape, color and type of safety shunt as follows:

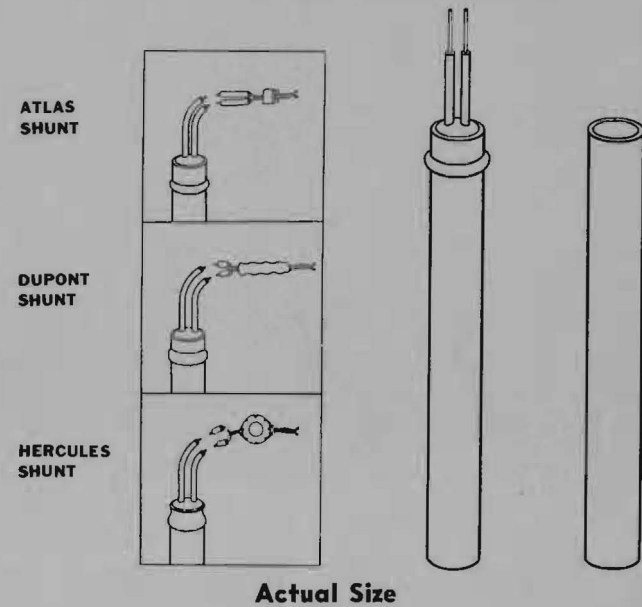

ATLAS

Clear lacquered copper shell, shaped as shown with a square lead clip safety shunt on bared end of leg wires.

DUPONT

Red lacquered shell, shaped as shown with metal foil safety shunt wrapped around bare end of leg wires.

HERCULES

Clear lacquered copper shell, with a concave end as indicated, eyelet or ring safety shunt on bare end of leg wires.

No. 8 Commercial Nonelectric Blasting Caps are the size and shape shown above. All makes have clear lacquered copper shells. Non-electric blasting caps may be used without regard to manufacture.

Identification of Blasting Caps

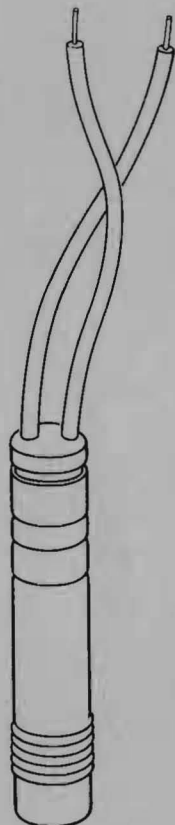

Actual Size

ELECTRIC DETONATOR MARK 1, MOD. 1

This is furnished for demolition purposes only with the Kit, Mine Conversion, Mark 7, Mod. 0 (11.15) and the Kit, Mine Conversion, Mark 8, Mod. 0 (11.16). This detonator is the size and shape shown above and its only use for demolition purposes is in connection with the Mine Conversion Kits, or to allow such conversions for miscellaneous shore demolition.

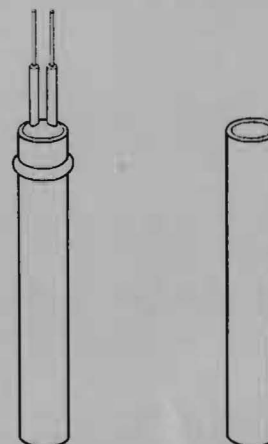

Actual Size

NO. 6 COMMERCIAL ELECTRIC AND NONELECTRIC BLASTING CAPS

These caps are not issued to Naval activities for detonating military explosives. They are the size and shape shown above. The No. 6 Commercial Electric Blasting Cap is designated for use in connection with Aircraft Chemical Tanks Mark 10, Mod. 0 (not elsewhere referred to in this publication).

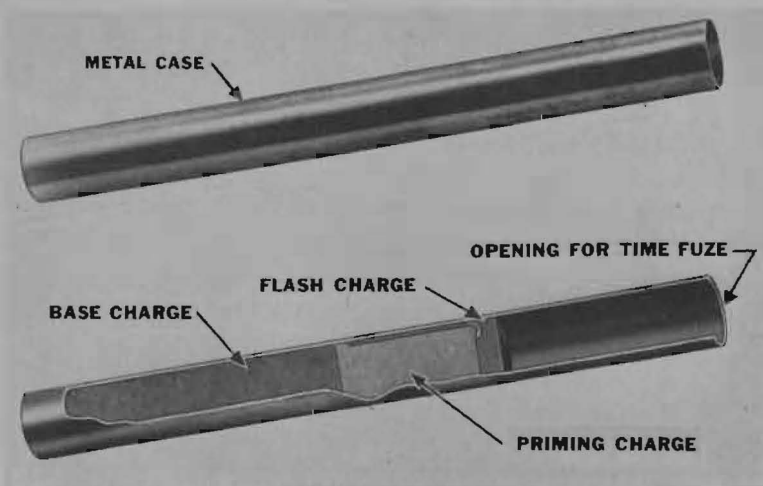

USE

Detonates explosives when a spit of flame enters its shell. Strong enough to detonate all demolition charges including Composition C (31.05) when the blasting cap is installed properly.

DESCRIPTION

Priming charge fires by flame and in turn detonates base charge of 13½ grains of PETN. See Appendix V concerning standardization of certain dimensions of this item.

CONNECTING ITEMS

Crimped on standard coupling bases or Fuse, Blasting, Time (12.01), using Crimper Cap (42.04, 42.05).

REFERENCES

FM 5-25, p. 20; TB Eng. 8, p. 10; TM 9-1940, p. 47-48; BH p. 38

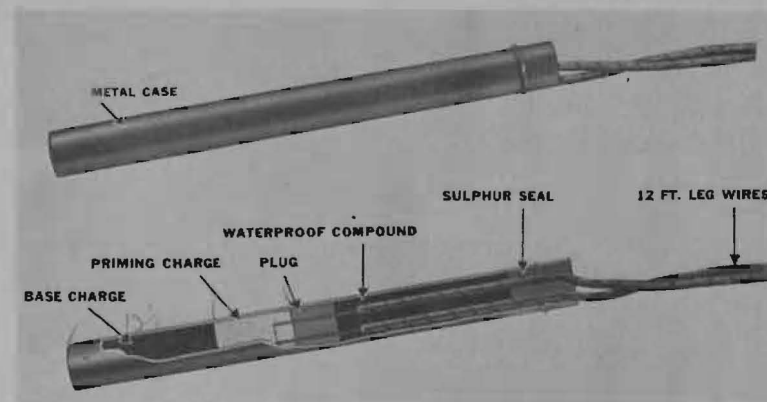

USE

Detonates explosives when electric current flows through its bridge wire. Strong enough to detonate all demolition charges including Composition C (31.05) when the blasting cap is installed properly.

DESCRIPTION

When current is passed through leg wires, bridge wire, strongly heated by current, ignites, fires the priming charge which detonates base charge of 13½ grains of PETN. See Appendix III concerning standardization of certain critical dimensions of this item.

CONNECTING ITEMS

Connects to Machines, Blasting, (13.01) or (13.03), Timer and Battery Box Mark 3 (15.10) or other electric source through length of suitable cable or wire.

REFERENCES

FM 5-25, p. 20; TM 9-1940, p. 47-48, BH p. 38

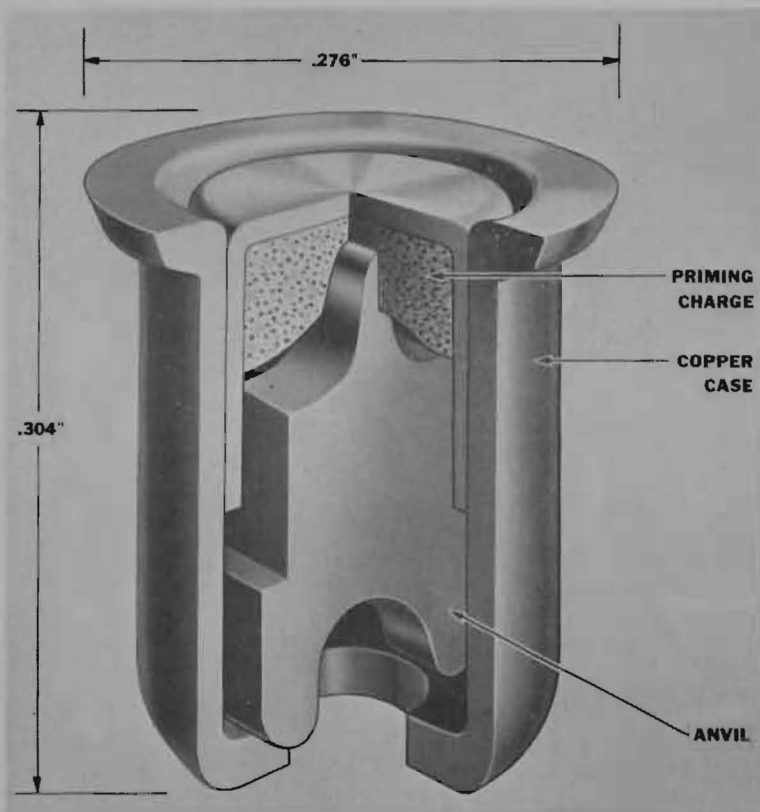

USE

Produces spit of flame by being struck by a firing pin such as that of a firing device. Each firing device requiring this kind of primer for use is issued with primer installed in the coupling base. The separately issued percussion cap primer is used for repriming firing devices used with indicator charges at training activities. This is done by replacing expended percussion cap primers in the coupling base.

DESCRIPTION

Copper case constructed as shown containing an extremely sensitive mercury fulminate mixture. Flashes when its cover is caused to pinch the mixture against metal anvil. See Appendix III concerning standardization of certain critical dimensions of this item.

CONNECTING ITEMS

Fits into coupling base of all mechanical firing devices having standard coupling base.

REFERENCES

FM 5-31

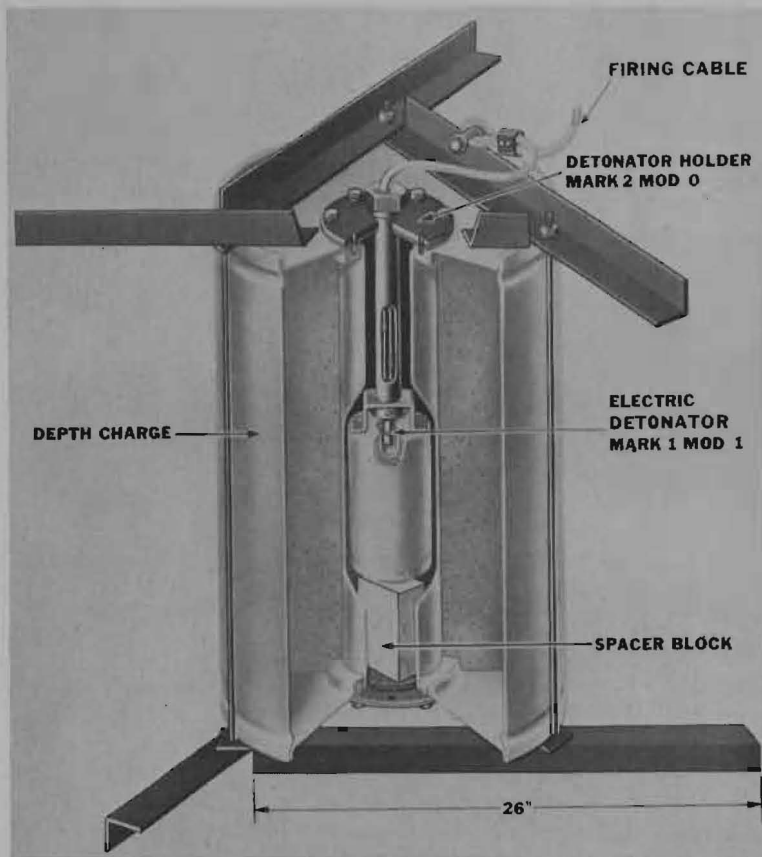

USE

Converts Depth Charges Mark 2, Mod. 2, Mark 3, Mark 6, Mod. 0 and Mark 6, Mod. 1 (provided they are already equipped with boosters) for use as electrically fired demolition charges or controlled mines. Anchor legs and complete initiating unit provided.

DESCRIPTION

Electric Detonator Mark 1, Mod. 1, mounted in Detonator Holder Mark 2, designed to replace standard depth charge pistol as shown.

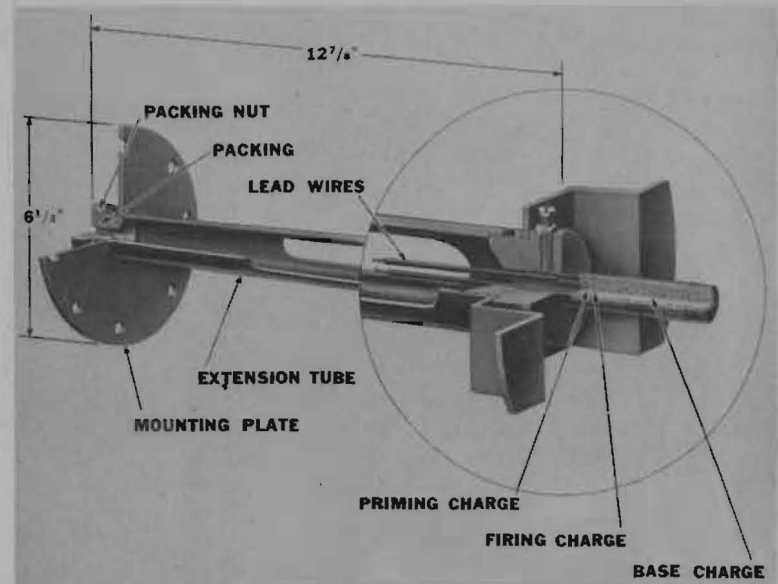

Wooden spacer block supported on felt pad holds booster against detonator holder. Packing gland provides water-tight seal for electric cable of .330 to .350 inch diameter which leads to detonator. Steel anchor legs, secured by tie rods, provided to prevent assembled charge from rolling in underwater currents. Clamp, thimble and mooring eye used to secure electric cable as shown. Cable, Demolition, Double Conductor (41.04) or other like diameter cable is required to fit in the packing gland but is not furnished as a part of the kit.

CONNECTING ITEMS

Detonated by Machine, Blasting (13.01) or (13.03), Timer and Battery Box, Mark 3 (15.10) or other electric source connected through Cable, Demolition, Double Conductor (41.04) of length required.

REFERENCES

OP 952; OP 1245.

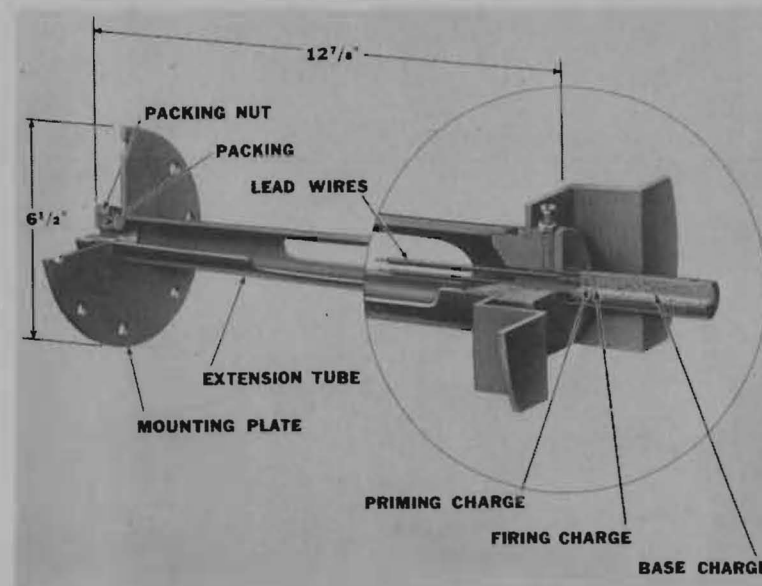
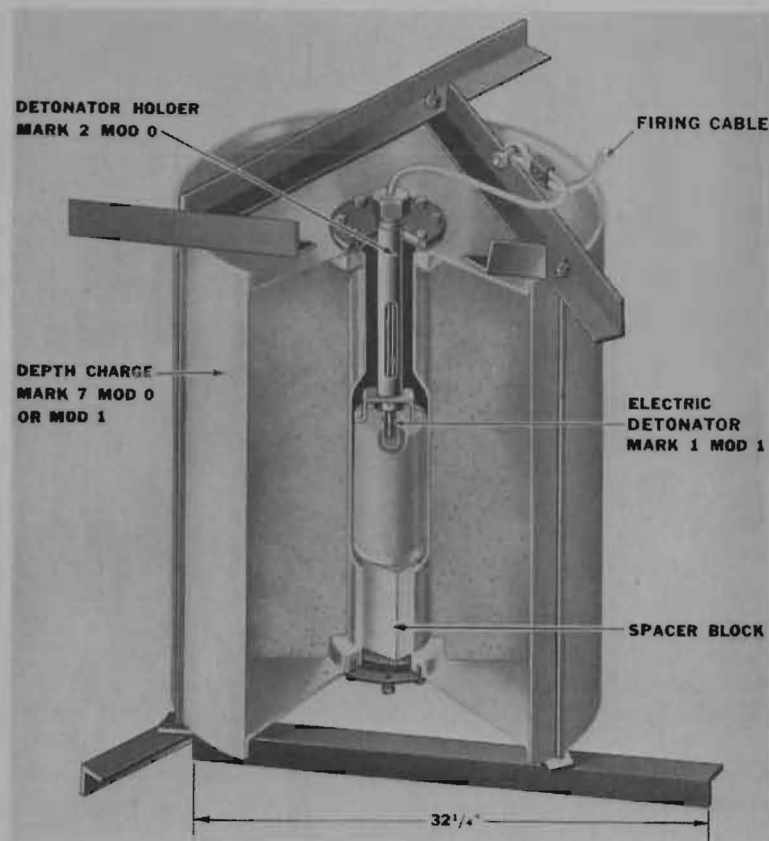

Wooden spacer block supported on felt pads holds booster against detonator holder. Packing gland provides watertight seal for electric cable of .330 to .350 inch diameter which leads to detonator. Steel anchor legs, secured by tie rods, provided to prevent assembled charge from rolling in underwater currents. Clamp, thimble and mooring eye used to secure electric cable as shown. Cable, Demolition, Double Conductor (41.04) or other like diameter cable is required to fit into the packing gland but is not furnished as a part of the kit.

USE

Converts Depth Charges Mark 7 and Mark 7, Mod. 1 (provided they are already equipped with boosters) for use as electrically fired demolition charges or controlled mines. Anchor legs and complete initiating unit provided.

DESCRIPTION

Electric Detonator Mark 1, Mod. 1, mounted in Detonator Holder Mark 2, is designed to replace standard depth charge pistol as shown.

CONNECTING ITEMS

Detonated by Machine, Blasting (13.01 or 13.03), Timer and Battery Box, Mark 3 (15.10), or other electric source connected through Cable, Demolition, Double Conductor (41.04) of length required.

REFERENCES

OP 952; OP 1245.

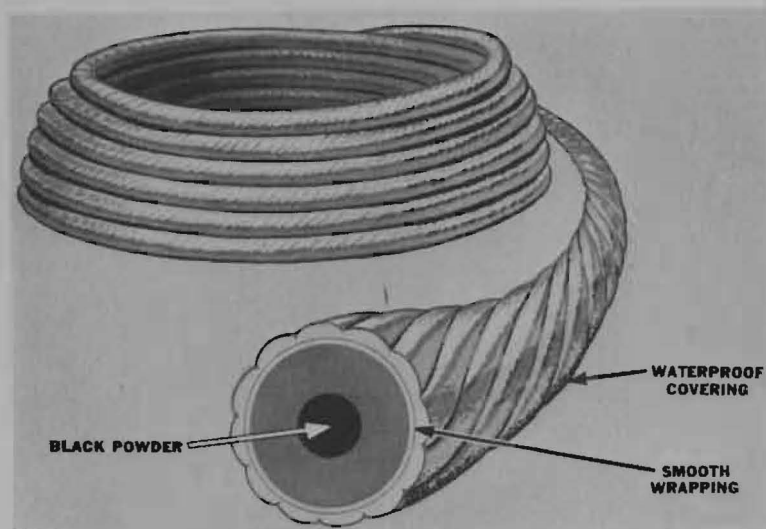

USE

Provides time delay when flame burns its way from one end to the other. Final spurt of flame from the fuse will initiate nonelectric blasting caps or starting mixtures of thermit devices.

DESCRIPTION

$\frac{1}{4}$ inch diameter fabric-covered cord containing black powder protected with bituminous waterproofing material. Burns from 30 to 45 seconds per foot, but may burn faster in very short lengths. Issued in 500 foot spools, each in a hermetically sealed metal can. Visual recognition is unreliable because some foreign detonating cords and burning-type fuses are very close in appearance to U. S. blasting time fuse. Therefore, use only known types until thoroughly tested by competent personnel.

CONNECTING ITEMS

Ignited by *Lighter, Fuse Pull Wire (14.30)* or *Lighter, Fuse, Weatherproof M2 (14.31)*. Causes detonation of *Caps, Blasting, Special Nonelectric (11.01)* crimped on over fuse. Ignites *Thermit Igniter Mark 1 Mod. 0 (38.01)* or *Thermit Unit, 10 lb. (38.10)*.

REFERENCES

FM 5-25, p. 23.



USE

Generates current for firing as many as 10 standard electric blasting caps connected in series.

DESCRIPTION

Electric generator mechanism in a weatherproof metal case. Operates by twisting handle clockwise with a quick twist. Handle detachable for safety during setup.

CONNECTING ITEMS

Fires Cap, Blasting, Special Electric (11.02) connected through suitable cable or wire.

REFERENCES

FM 5-25 p. 16, BH p. 53.

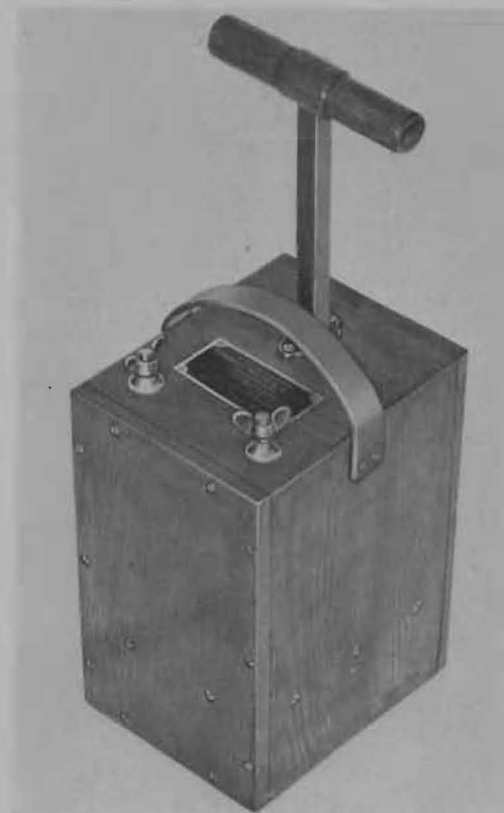

USE

Generates current for firing as many as 30 standard electric blasting caps connected in series.

DESCRIPTION

Electric generator mechanism in a wooden case. Operates by raising handle and pushing down rapidly, full length of stroke.

CONNECTING ITEMS

Fires Cap, Blasting, Special Electric (11.02) connected through suitable cable or wire.

REFERENCES

FM 5-25 p. 16; BH p. 53.

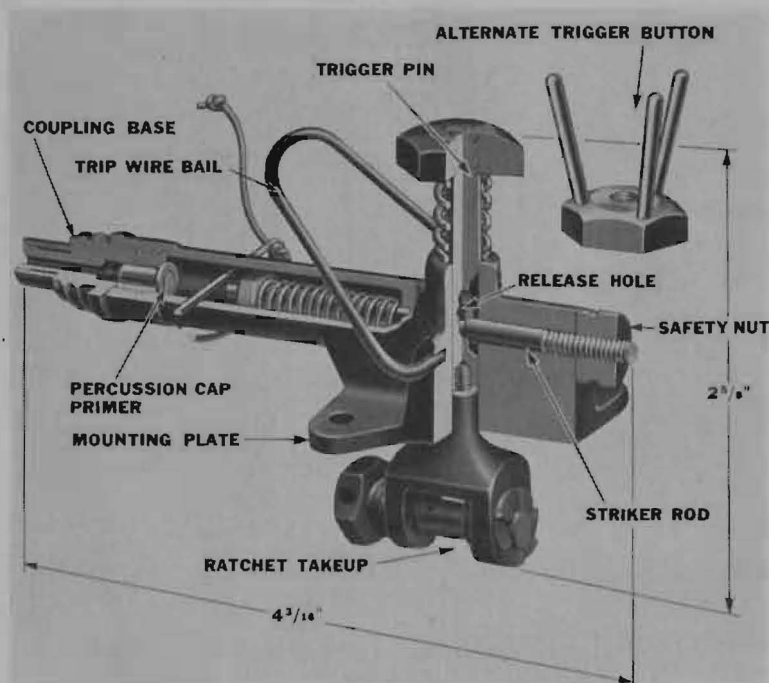
**USE**

Used in booby traps. Application or release of pressure or tension will produce first flash for detonation of nonelectric blasting cap. Actuation of this firing device requires force of from 11 to 16 pounds.

DESCRIPTION

Moving trigger pin down to release hole, or releasing trigger pin so it moves up to release hole, allows striker rod to travel forward, firing cup primer. Device has cast brass body, mounting plate, alternative trigger buttons with and without extension arms, 50 feet of trip wire, bail, and trip wire ratchet reel provided in the smallest unit package.

CONNECTING ITEMS

Cap, Blasting, Special Nonelectric (11.01) to be crimped onto coupling base. Fits any charge with standard threaded activator well. Detonates Cord, Detonating (17.01, 17.02, 17.03) properly attached to blasting cap.

REFERENCES

OTI A2-44; OTI A5-44.

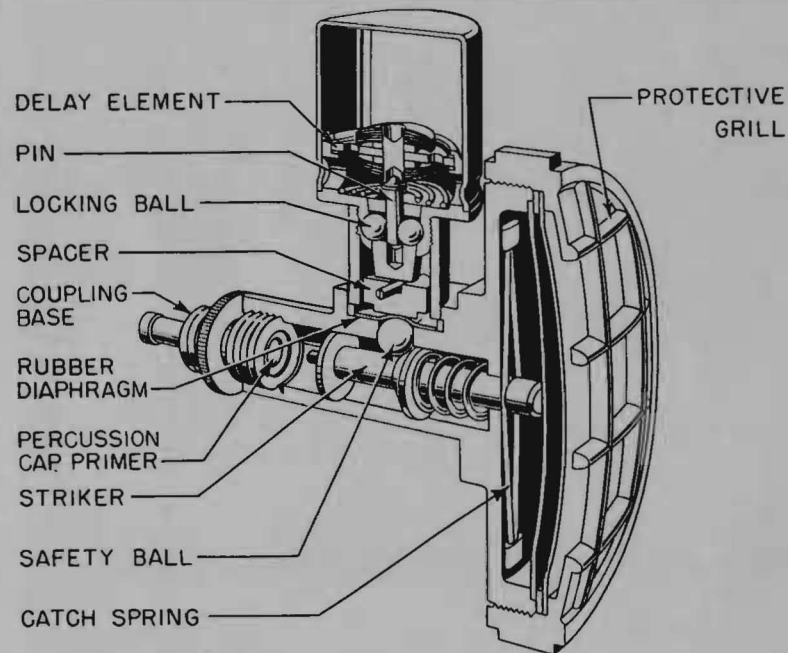
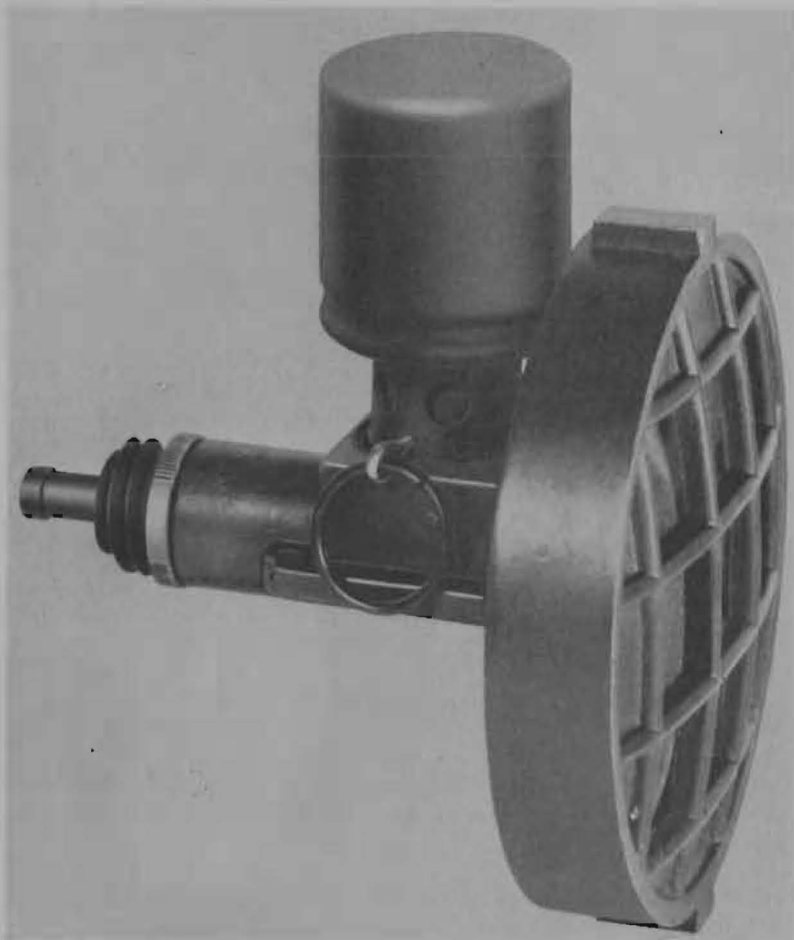

DESCRIPTION

Concussion of initiating charge causes a snap diaphragm contained in the zinc die-cast body to snap through dead center and drive a firing pin into a percussion cap. Basic design same as Army "Concussion Detonator T1." Each firing device is supplied in an hermetically sealed tin can with one delay Arming Cell Mark 1 of various Mods, 0 to 4 inclusive, corresponding to a nominal time delay in average salt water of 9, 15, 30, 60 and 90 minutes. The actual time varies according to temperature. Each container is appropriately marked to indicate the type of arming cell on the firing device. See next page for delay time and corresponding official designation.

CONNECTING ITEMS

Cap, Blasting, Special Nonelectric (11.01), to be crimped onto coupling base.

Fits any standard threaded activator well. When used in water, Booster Mark 13 Mod. 0 (22.05) is especially useful to waterproof blasting caps.

REFERENCES

NOLM 5782; TB 5-25-4.

USE

Designed for sympathetic detonation of charges either in air or in water up to twelve feet deep. Fires a nonelectric blasting cap crimped in the conventional manner to a coupling base.

Firing Device, Demolition, Mark 6 Mod. 0 with Arming Cell

FIRING DEVICE, DEMOLITION, MARK 6 MOD. 0 WITH ARMING CELL MARK 1 MOD. 0 14.02

Has arming delay of approximately 9 minutes in average sea
water at 60°F

FIRING DEVICE, DEMOLITION, MARK 6 MOD. 0 WITH ARMING CELL MARK 1 MOD. 1 14.03

Has arming delay of approximately 15 minutes in average sea
water at 60°F

FIRING DEVICE, DEMOLITION, MARK 6 MOD. 0 WITH ARMING CELL MARK 1 MOD. 2 14.04

Has arming delay of approximately 30 minutes in average sea
water at 60°F

FIRING DEVICE, DEMOLITION, MARK 6 MOD. 0 WITH ARMING CELL MARK 1 MOD. 3 14.05

Has arming delay of approximately 60 minutes in average sea
water at 60°F

FIRING DEVICE, DEMOLITION, MARK 6 MOD. 0 WITH ARMING CELL MARK 1 MOD. 4 14.06

Has arming delay of approximately 90 minutes in average sea
water at 60°F

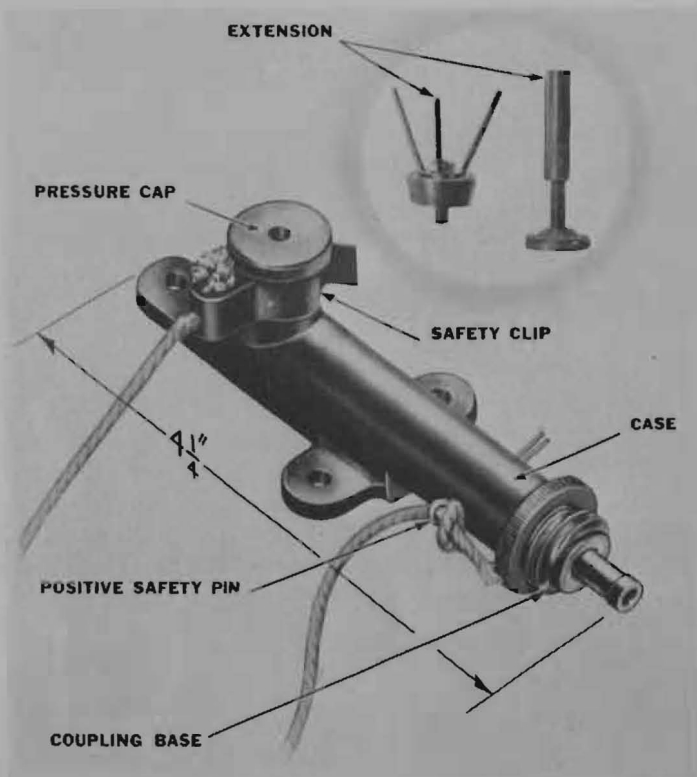

USE

Used in booby traps. Pressure of from 25 to 40 pounds produces first flash for detonation of nonelectric cap.

DESCRIPTION

Olive drab die cast metal body. Pressure on pressure cap releases striker, firing primer cap. Smallest unit package contains 5 firing devices, including three prong-type extensions and two adjustable sleeve extensions.

CONNECTING ITEMS

Cap, Blasting, Special Nonelectric (11.01), to be crimped onto coupling base.

Fits any charge with standard threaded activator well.

Detonates Cord, Detonating (17.01, 17.02, 17.03) properly attached to blasting cap.

REFERENCES

FM 5-31, p. 53.01; FM 5-30 par. 85-88; FM 5-25 p. 30; TM 9-1940 p. 44

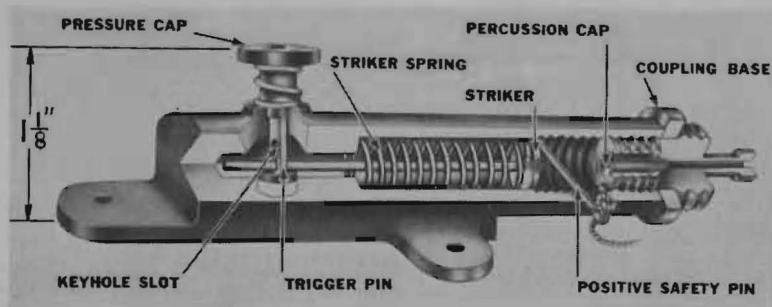

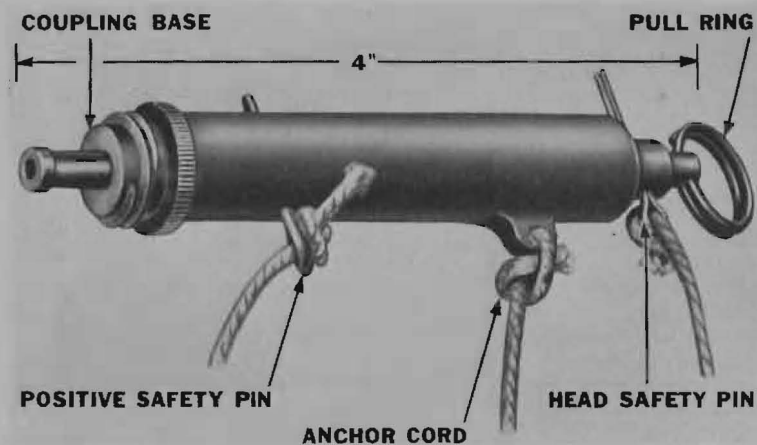
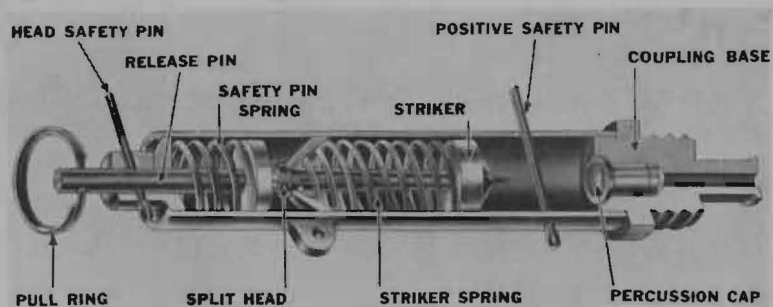

USE

Used in booby traps. Pull of at least 3 pounds produces first flash for detonation of nonelectric cap. Being replaced for some issues by Firing Device, Pull Friction Type, M2 (14.19).

DESCRIPTION

Olive drab die cast metal body. Pull on pull ring releases spring loaded striker firing percussion cap. Smallest unit package contains 5 firing devices, including 2 spools each carrying 80 feet of trip wire.

CONNECTING ITEMS

Cap, Blasting, Special Nonelectric (11.01), to be crimped onto coupling base.

Fits any charge with standard threaded activator well.

Detonates Cord, Detonating (17.01, 17.02, 17.03) properly attached to blasting cap.

REFERENCES

FM 5-31 p. 53.02; FM 5-30 p. 51; FM 5-25 p. 30; TM 9-1940 p. 42

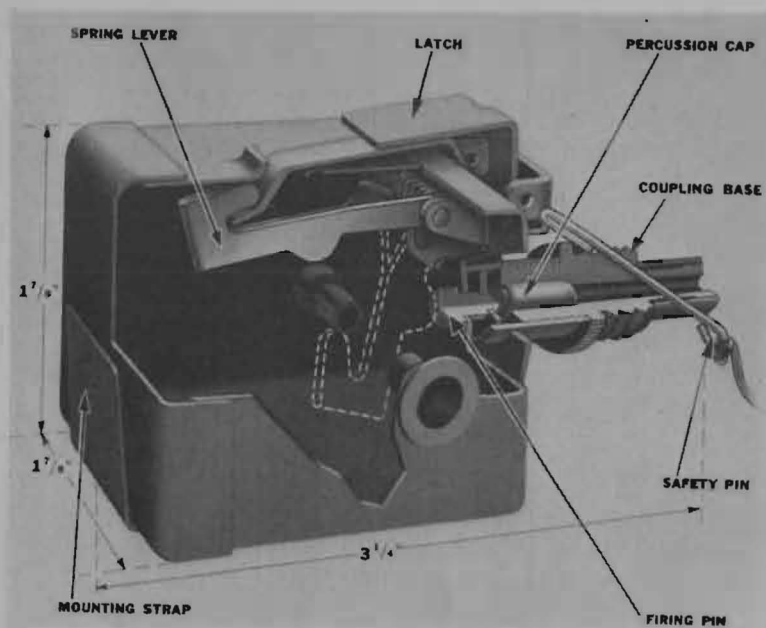

USE

Used in booby traps. Release of pressure over 2 pounds produces first flash for detonation of nonelectric cap.

DESCRIPTION

Removing pressure on latch releases spring lever, which swings down, striking the firing pin and firing the percussion cap. Made of alloy metal as shown with mounting strap on bottom of case.

CONNECTING ITEMS

Cap, Blasting, Special Nonelectric (11.01) to be crimped onto coupling base.

Fits any charge with standard threaded activator well.

Detonates Cord, Detonating (17.01, 17.02, 17.03), when properly attached to blasting cap.

REFERENCES

FM 5-31 p. 53.03; FM 5-30 p. 58; FM 5-25 p. 30; TM 9-1940 p. 45-47

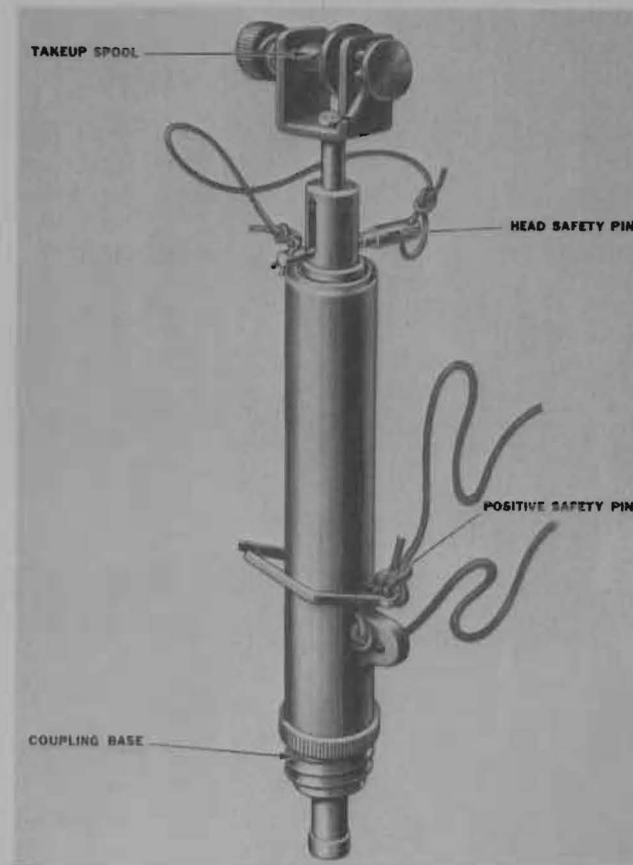
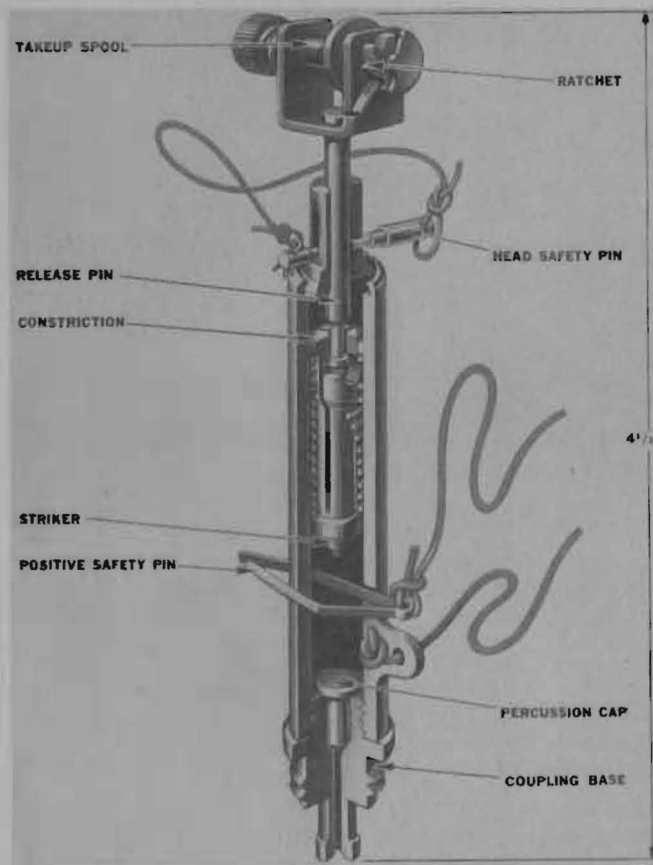

USE

Used in booby traps. Application of pull of over 10 pounds or release of 6 to 10 pounds tension from trip wire produces first flash for detonation of nonelectric cap.

DESCRIPTION

Pulling or releasing release pin opens constriction, which frees striker to fire percussion cap. Olive drab die cast metal body. Smallest unit package contains 5 firing devices, including 2 spools each carrying 80 feet of 28 gauge trip wire.

CONNECTING ITEMS

Cap, Blasting, Special Nonelectric (11.01) to be crimped onto coupling base. Fits any charge with standard threaded activator well. Detonates Cord, Detonating (17.01, 17.02, 17.03), properly attached to blasting cap.

REFERENCES

FM 5-31 p. 53.06; FM 5-25 p. 30; TM 9-1940 p. 37

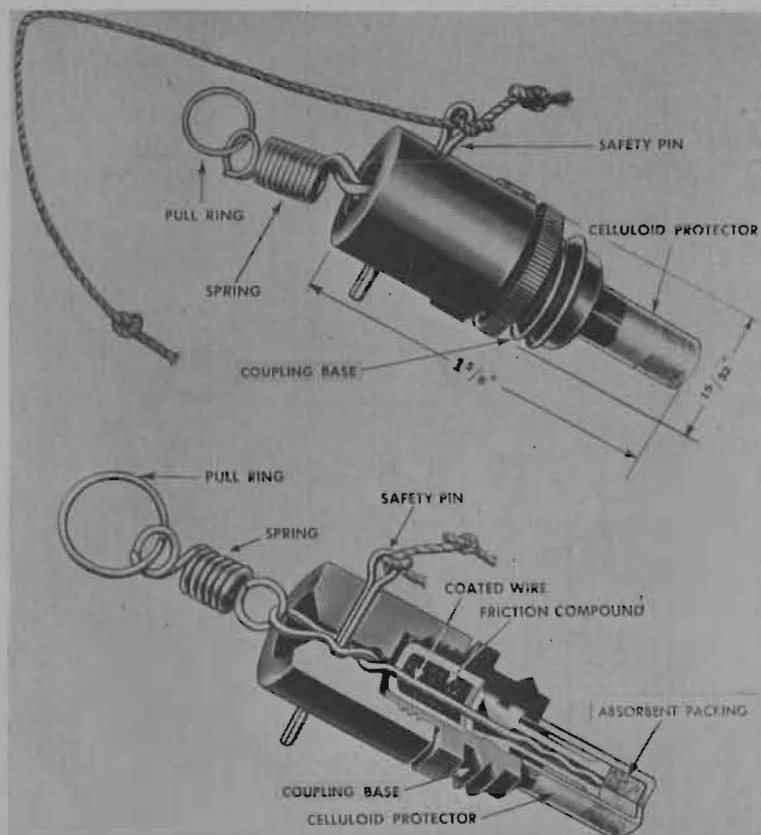
**USE**

Used in booby traps. Pull of 3 to 9 pounds produces first flash for detonation of nonelectric blasting cap. May be used under water.

DESCRIPTION

Pulling ring extends spring which jerks coated wire, igniting friction compound and firing flash compound. Black plastic body with base threaded for standard activator well. Flash hole is protected from moisture by protector containing absorbent packing. This protection is removed when the device is installed. Smallest unit package contains 5 firing devices, including 2 spools each carrying 80 feet of 28 gauge trip wire.

CONNECTING ITEMS

Cap, Blasting, Special Nonelectric (11.01) to be crimped onto base. Fits any charge with standard threaded activator well.
Detonates Cord, Detonating, (17.01, 17.02, 17.03) when properly attached to blasting cap.

REFERENCES

FM 5-25 p. 30

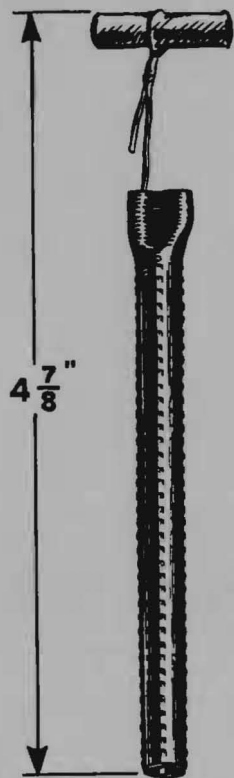
**USE**

Ignites safety fuse. Used where there is no danger of wetting the fuse. No longer issued to Naval activities. Lighter, Fuze, M2 (14.31) is recommended for adverse weather conditions or for wet work.

DESCRIPTION

Paper tube containing friction powder. Pulling handle ignites the powder, which in turn fires safety fuse inserted in end of lighter. Known commercially as pull wire fuse lighter.

CONNECTING ITEMS

Fits on end of Fuse, Blasting, Time (12.01).

REFERENCES

FM 5-30 p. 62; FM 5-25 p. 26; BH p. 49

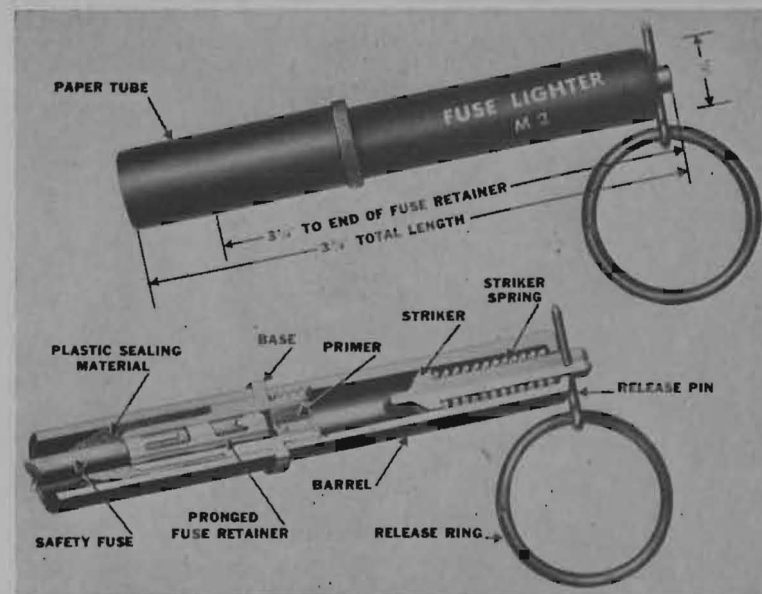
**USE**

Ignites safety fuse under water. Reliable for use under all weather conditions.

DESCRIPTION

Dull black metal body. Pulling release pin fires primer cap igniting safety fuse. Plastic sealing material provided for waterproofing.

CONNECTING ITEMS

Fits on end of Fuse, Blasting, Time (12.01).

REFERENCES

TB 5-25-2, TB Eng 8 p. 15

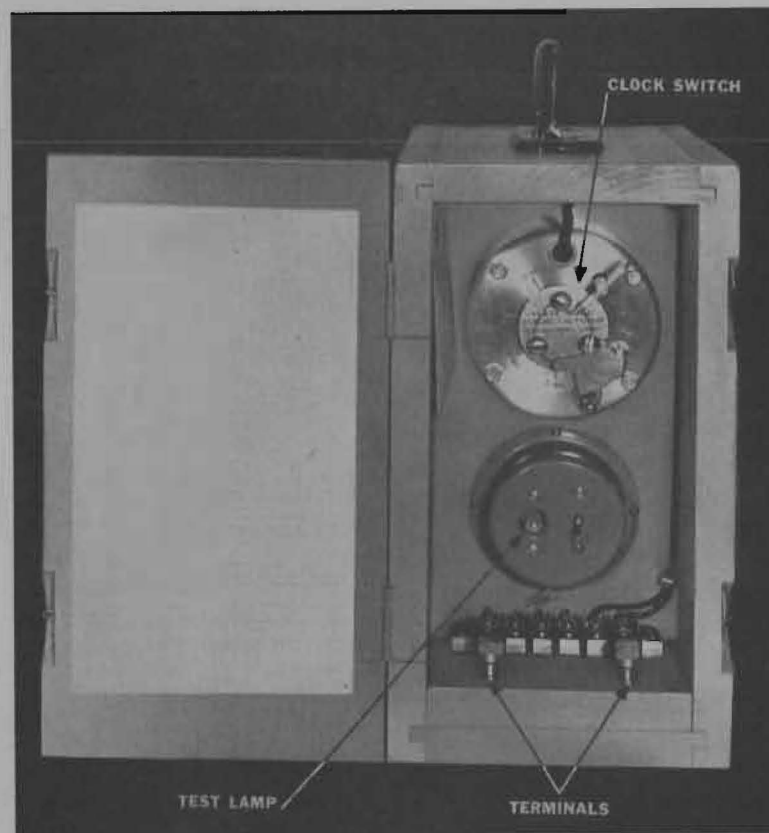

DESCRIPTION

Wooden box containing clock-controlled switch, battery test lamp and terminal block in one end, and with space for eight Number 6 Dry Cells in other end. Furnished without dry cells. For each Timer and Battery Box Mark 3 Mod. 0 package the following are included: 2 spare battery test lamps, 1 spare winding key, 7 battery connectors, 3 cork plugs.

CONNECTING ITEMS

Connects electrically to 8 No. 6 Dry Cells. (Required for operation.)
 Fires Cap. Blasting. Special Electric (11.02) connected through suitable cable or wire.

REFERENCES

OP 1012; OCL A78-43

USE

Closes electric circuit after time delay to send current through electric blasting caps. Time delay adjustable in field from 15 minutes to 5 hours. This item is only issued where special conditions require it (p. 10).

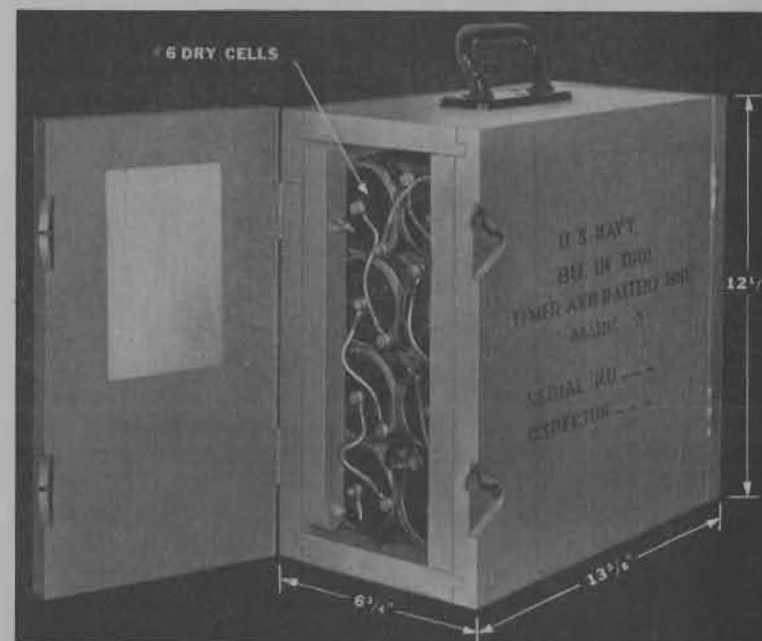

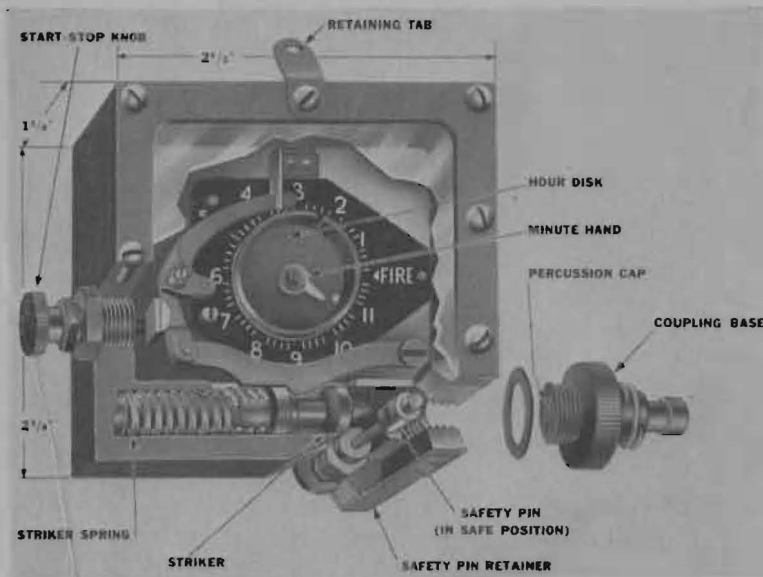

USE

After the delay time has elapsed, produces a spit of flame for detonating a nonelectric blasting cap. Time delay adjustable in field up to 11 1/2 hours. Minimum allowable setting is 10 minutes. Waterproof to depth of 20 feet. This firing device is only issued where special conditions require it (p. 10).

DESCRIPTION

Metal case with transparent cover contains luminous marked clock and firing mechanism, consisting of tripping lever that releases spring loaded striker, firing percussion cap. Smallest unit package includes 1 screw driver, coil of securing wire 19 inches long.

CONNECTING ITEMS

Cap, Blasting, Special Nonelectric (11.01), to be crimped onto coupling base.

Fits any charge with standard threaded activator well.

Detonates Cord, Detonating (17.01, 17.02, 17.03) when properly attached to cap.

For waterproof, well protected detonating unit use with **Booster Mark 13 Mod. 0** (22.05) containing Cap, Blasting, Special Nonelectric (11.01).

REFERENCES

OHI A4 44

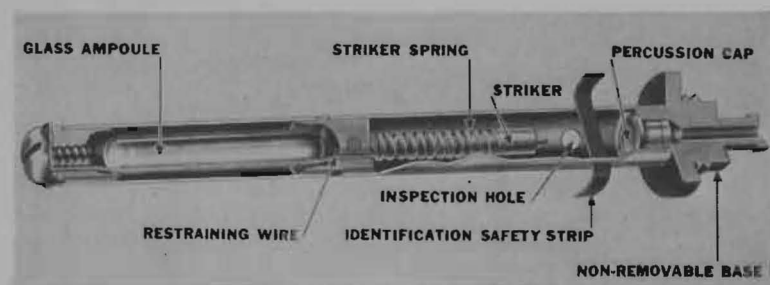
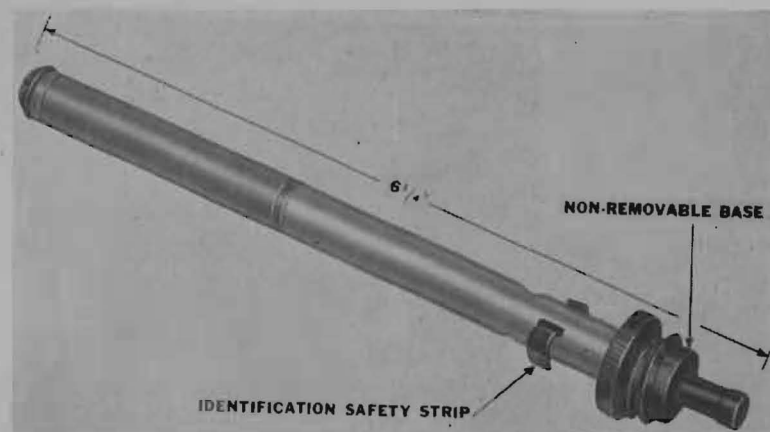

USE

After the delay time has elapsed, produces a spit of flame for detonating a nonelectric blasting cap. Various models available with five fixed time delays, color coded.

DESCRIPTION

Upper half of body soft copper, lower half brass. Pressing upper half of body crushes glass ampoule, releasing corrosive liquid which eats through restraining wire and releases spring loaded striker, firing percussion cap. The five delays which are produced are subject to temperature variations and a chart is included with each to provide the information necessary. However, at 70°F, the six models have the following nominal delays:

Red, 14 minutes; White, 1 3/4 hours; Green, 4 hours; Yellow, 6 1/4 hours; Blue, 12 1/2 hours. Furnished in boxes of ten, assorted as follows: 2 Red, 3 White, 3 Green, 1 Yellow, and 1 Blue.

CONNECTING ITEMS

Cap, Blasting Special Nonelectric (11.01), to be crimped onto coupling base.

Fits any charge with standard threaded activator well.

Detonates Cord, Detonating (17.01, 17.02, 17.03) when properly attached to cap.

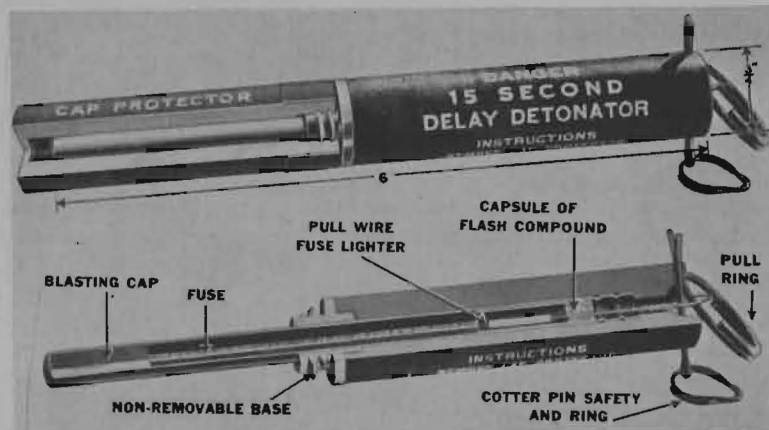

USE

Waterproof device initiates delayed-firing of charges. Particularly useful during assault demolitions.

DESCRIPTION

Olive drab plastic body. Pulling ring ignites flash compound and starts powder train delay which fires detonator 15 seconds later. Detonator same strength as Special Blasting Caps (11.01, 11.02).

CONNECTING ITEMS

Connects to any charge with a standard threaded activator well.

Detonates Cord, Detonating (17.01, 17.02, 17.03) when properly attached to detonator.

REFERENCES

FM 5-31 p. 53.05; IB 143

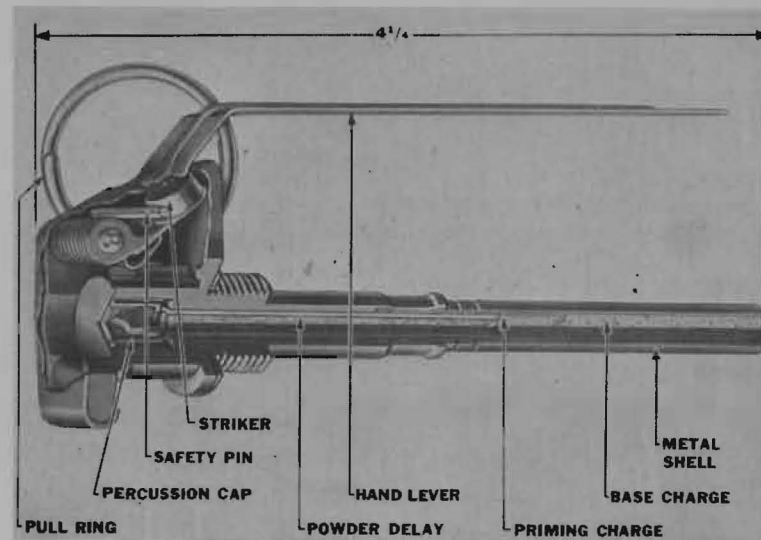

USE

Detonates hand grenades, Demolition Block M2, or Detonating Cord with 10 to 35 pound pull from trip wire or on release of hand lever.

DESCRIPTION

Removing safety pin and hand lever frees striker, detonating percussion cap and starting four second powder train which detonates 20 grain charge. Constructed of metal as shown, with threads for standard activator well, but with case too thick to fit threaded activator wells except those listed below.

CONNECTING ITEMS

Detonates Grenade, Hand, Offensive, Mark III A2 (36.20) or Block Demolition, M2 (31.04) when screwed into activator well. Detonates Cord, Detonating (17.01, 17.02, 17.03) when properly attached to detonator case.

REFERENCES

FM 5-30 p. 71

USE

Explodes throughout entire length with sufficient force to detonate simultaneously any arrangement of charges properly connected for detonation. Water resistant fabric cover provides tensile strength of approximately 113 pounds.

DESCRIPTION

Core of high explosive, PETN wrapped in a single fabric cover, 5 threads per inch, with a rough waxy finish. Furnished in 500 foot lengths in hermetically sealed cans. Weighs 19 pounds per 1000 feet. This type of Cord, Detonating is only issued where special conditions justify it (p. 10).

CONNECTING ITEMS

Detonated by Cap, Blasting, Special Electric (11.02) or Cap, Blasting, Special Nonelectric (11.01) properly attached to detonating cord.

REFERENCES

FM 5-25 p. 24; TM 9-1940 p. 33; TB Eng 8 p. 11-12-13; BH p. 46

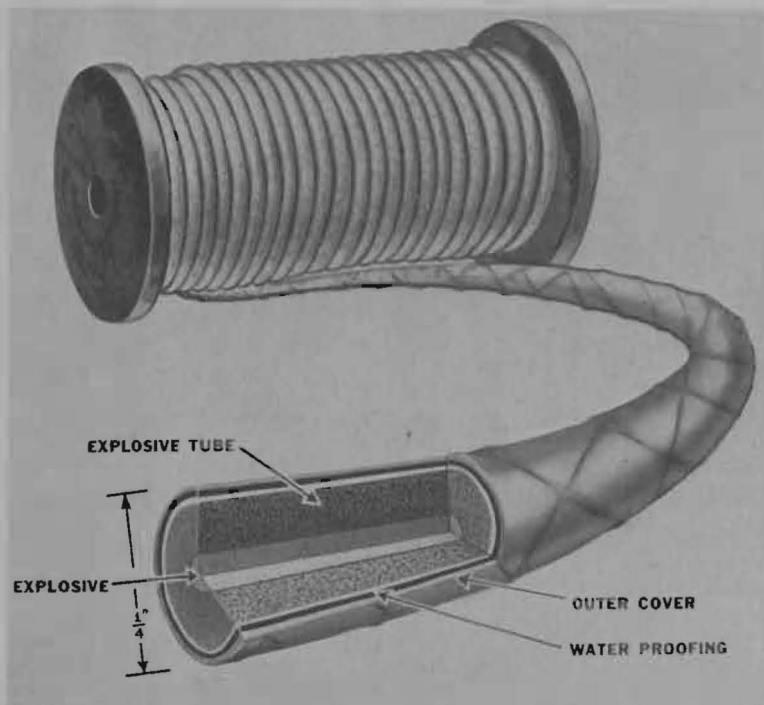
**USE**

Explodes throughout entire length with sufficient force to detonate simultaneously any arrangement of charges properly connected for detonation. More resistant to abrasion than plain detonating cord (17.01) and higher tensile strength of 160 pounds.

DESCRIPTION

Core of high explosive, PETN wrapped in a fabric cover, 10 threads per inch, having a rough waxy finish. Furnished in 500 foot lengths in hermetically sealed cans. Weighs 20 pounds per 1000 feet. As soon as adequate stocks can be obtained this type of Cord, Detonating will be issued in all cases except where special conditions call for the plain (17.01) or wirebound (17.03) types.

CONNECTING ITEMS

Detonated by Cap, Blasting, Special Electric (11.02) or Cap, Blasting, Special Nonelectric (11.01) properly attached to detonating cord.

REFERENCES

FM 5-25 p. 24; TM 9-1940 p. 33; TB Eng 8 p. 11-12-13; BH p. 46

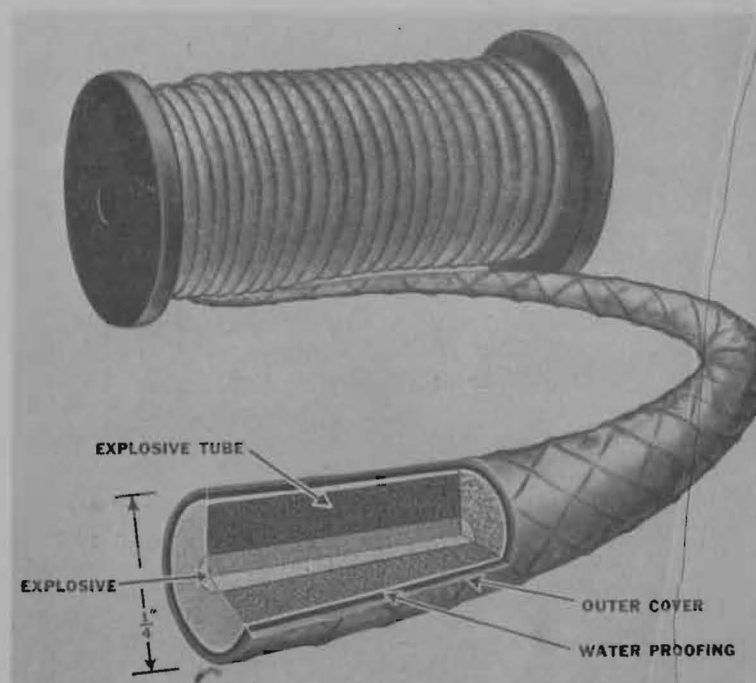

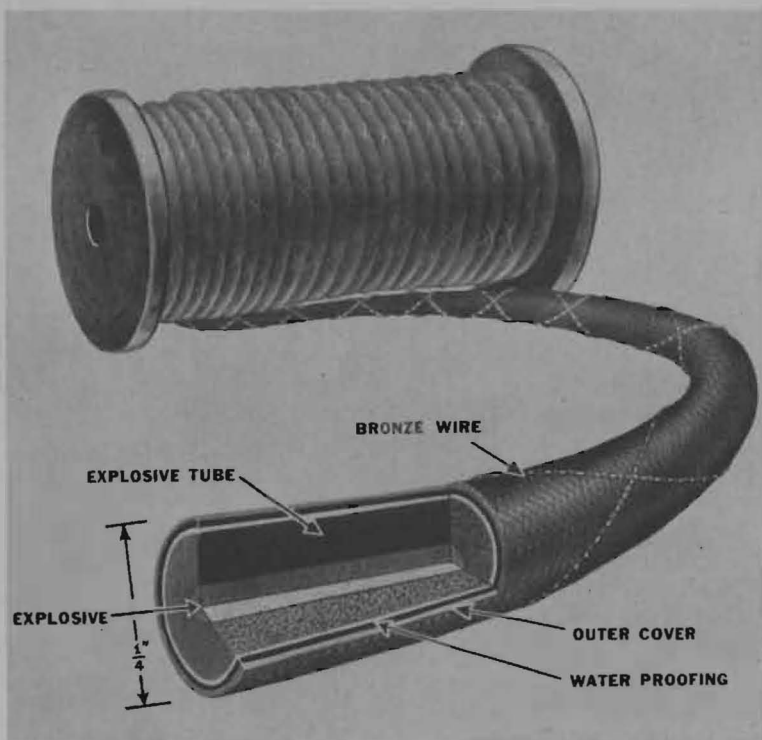

USE

Explodes throughout its entire length with sufficient force to detonate simultaneously any arrangement of charges properly connected for detonation. Highly resistant to abrasion and shearing, with tensile strength of 220 pounds. More difficult to tie or crimp than other types.

DESCRIPTION

Core of high explosive, PETN wrapped in a waterproof double textile covering with interwoven bronze wire reinforcing. Furnished in 500 foot lengths in hermetically sealed cans. Weighs 35 pounds per 1000 feet. This type of cord, detonating is only issued where special conditions justify it (p. 10).

CONNECTING ITEMS

Detonated by Cap, Blasting, Special Electric (11.02) or Cap Blasting, Special Nonelectric (11.01) properly attached to detonating cord.

REFERENCES

FM 5-25 p. 24; TM 9-1940 p. 33; BH p. 46

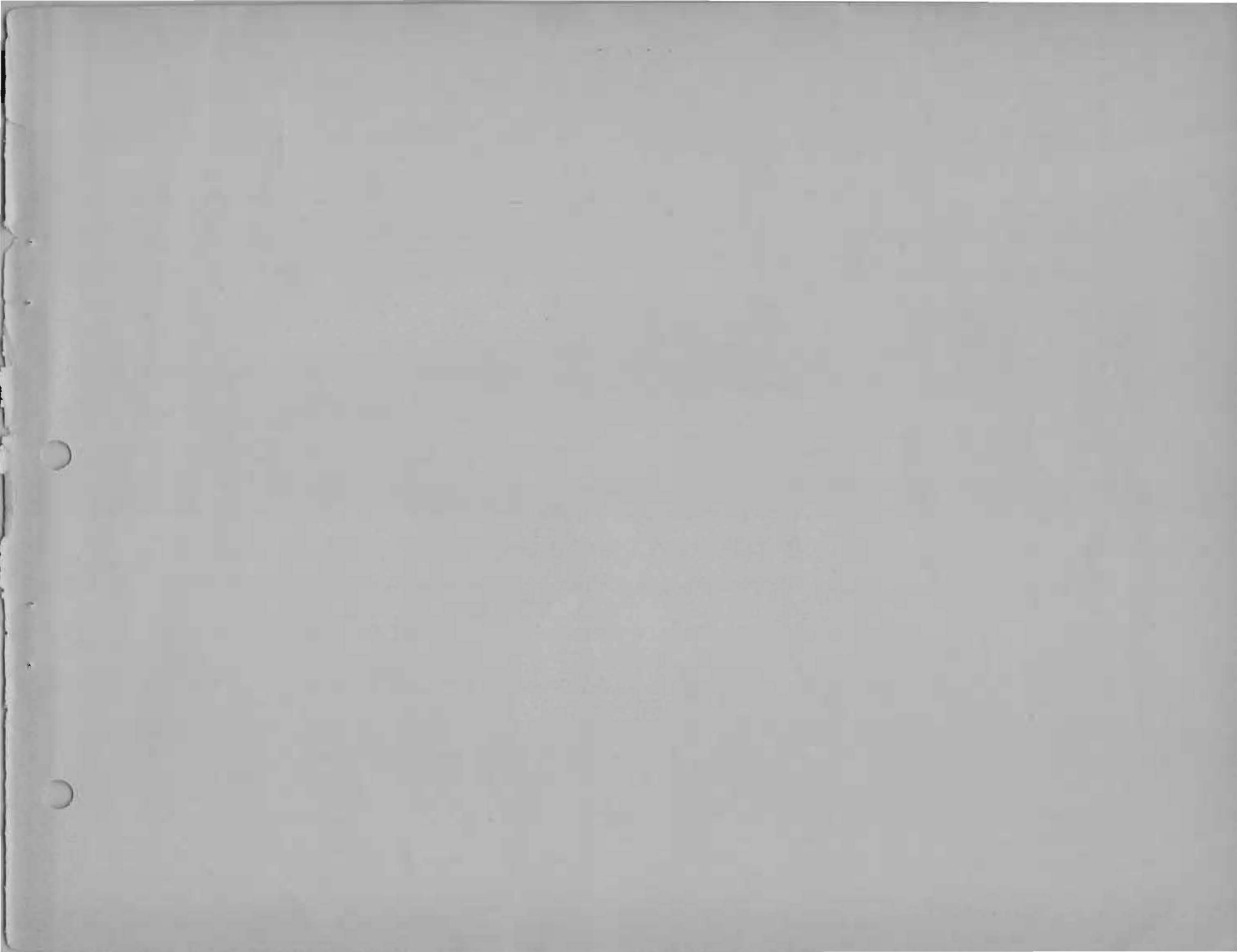

This chapter describes equipment especially designed for detonating demolition charges other than those having standard threaded activator wells.

Section 1—DEMOLITION FUZES

These fuzes are designed to attach to certain demolition material other than by screwing into standard threaded activator wells and are designed to detonate such demolition charges when so fitted in place.

Section 2—DEMOLITION BOOSTERS

These boosters are used to increase the explosive force of initiators to such an extent that high order detonation of main charges will result. This section excludes boosters furnished for demolition purposes only as a part of some other demolition item.

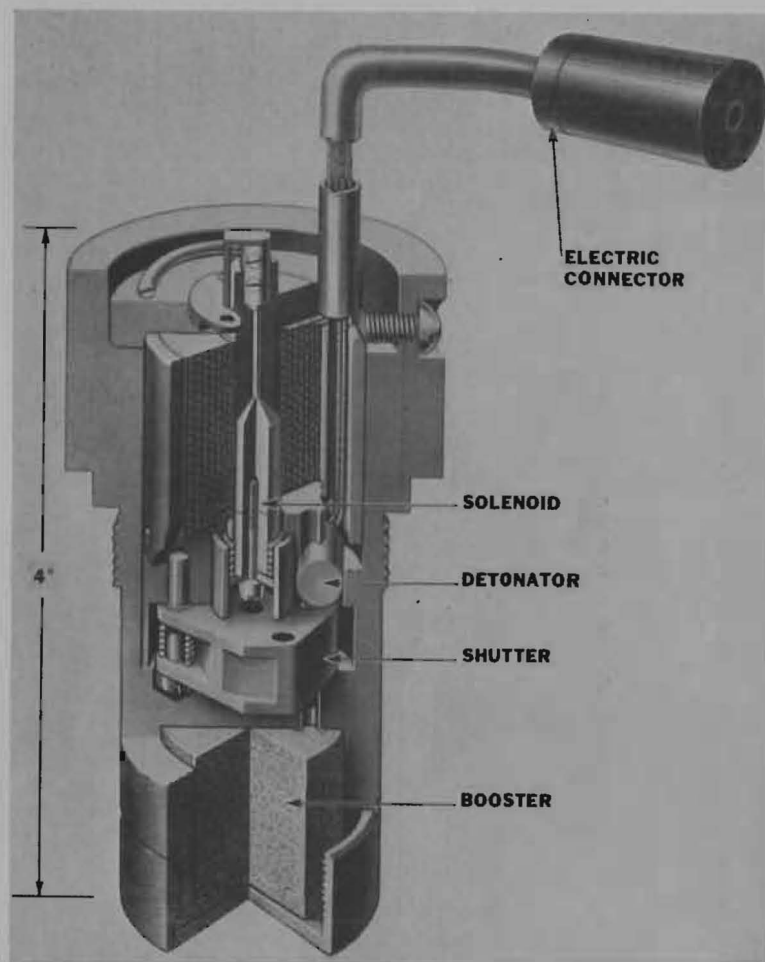

USE

Provides electrical arming and firing by two independent electric circuits, for detonation of charges having 1 $\frac{3}{4}$ " threaded demolition fuze seat. Not reliable for use under water.

DESCRIPTION

Metal body containing detonator and booster. Armed by 12 volts of electricity causing a solenoid to release a spring operated shutter, which aligns the detonator and booster for firing. Fired by a separate electric current.

CONNECTING ITEMS

Attaches to Demolition Charge Mark 9 Mod. 0 (31.21) or Demolition Charge Mark 9 Mod. 1 (31.22).

USE

Provides electrical arming and firing by two independent electric circuits, for detonation of charges having 1 $\frac{3}{4}$ " threaded demolition fuze seat. Usable under water.

DESCRIPTION

Same as Fuze Mark 143 Mod. 0 except that it has a heavier detonator charge and waterproof connections. Metal body containing detonator and booster. Armed by 10 volts of electricity causing a solenoid to release a spring operated shutter, which aligns the detonator and booster for firing. Fired by a separate electric current.

AUXILIARY COMPONENTS

Attaches to Demolition Charge Mark 9 Mod. 0 (31.21) or Demolition Charge Mark 9 Mod. 1 (31.22).

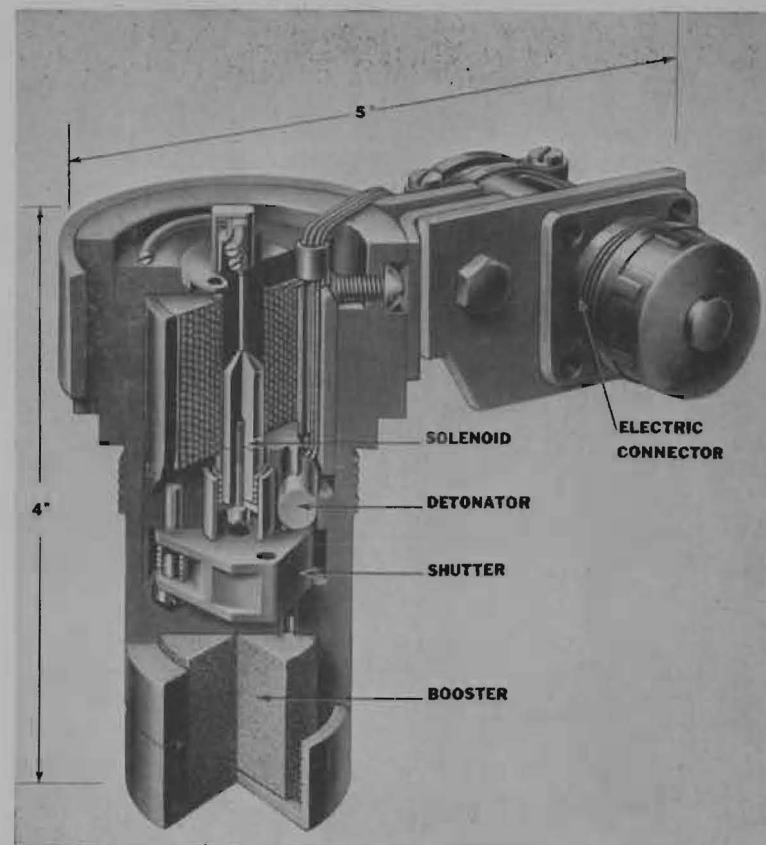

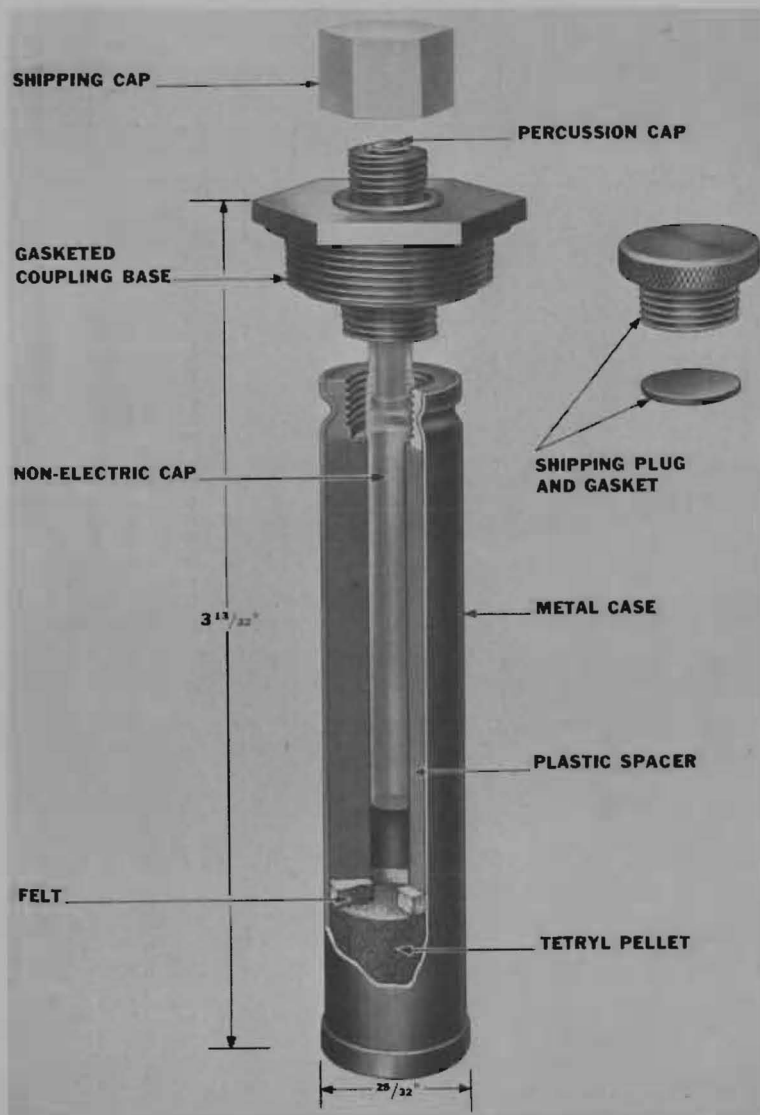

USE

Waterproof booster. When used with any waterproof firing device, provides complete waterproof initiating unit for general purposes. Stocks not yet available except in limited quantities.

DESCRIPTION

5.8 grams tetryl in cylindrical metal case with standard threaded cap well. Includes special gasketed coupling base. Usable as deep as 20 feet under water.

CONNECTING ITEMS

Attaches to Demolition Charge Mark 2 Mod. 1 (31.20) and fits into the cap protector supplied with Demolition Charge Mark 8 Mod. 0 (33.01).

Receives any standard threaded firing device having removable coupling base. Can be used to detonate Cord, Detonating (17.01, 17.02, 17.03) or Composition C (31.05).

Explosive charges, indicator charges, and incendiary charges are included in this chapter. This chapter describes available main charges and assemblies including main charges ranging in functional completeness all the way from charges which require considerable of the equipment elsewhere listed for operation; to charges and assemblies which are complete operating units within themselves. The chapter is divided into sections, classified according to use or handling methods, as follows:

Section 1—HAND PLACED POINT CHARGES

In this section are described demolition charges generally handed by one man and which provide an explosive charge concentrated in one location. Some of these charges are designed to be stacked together for use.

Section 2—LARGE POINT CHARGES AND THEIR ASSEMBLIES

These charge assemblies are designed to be placed by crews or by special equipment to provide a large quantity of explosive concentrated in one location.

Section 3—LINE CHARGES AND THEIR ASSEMBLIES

These charges are designed to provide an explosion distributed along a line. The length and the charge weight for a particular length may be varied considerably by the method of assembly and the type of charge.

Section 4—CAVITY CHARGES

This section describes charges and charge containers which control and direct a large part of the force of the explosion to provide a single jet or a continuous line jet of explosive force having great penetrating power.

Section 5—ANTITANK MINES

The mines listed are standard complete operating assemblies for use as antivehicular charges.

Section 6—ANTIPERSONNEL MINES

The charges described are for use against or for the detection of personnel and are complete operating assemblies.

Section 7—ANTIBOAT MINES

Those charges are designed to be placed by shore activities for use against naval craft in shallow water. Standard naval mines laid by ships or aircraft are not included in this category.

Section 8—INCENDIARY CHARGES

These charges are designed for use where destruction by burning is desirable.

Section 9—DESTRUCTORS, SPECIAL CHARGES AND THEIR ASSEMBLIES

Included in this classification are charges or assemblies of charges which are designed to destroy certain equipment, and other special purpose charges which have uses other than those described in the previous sections.

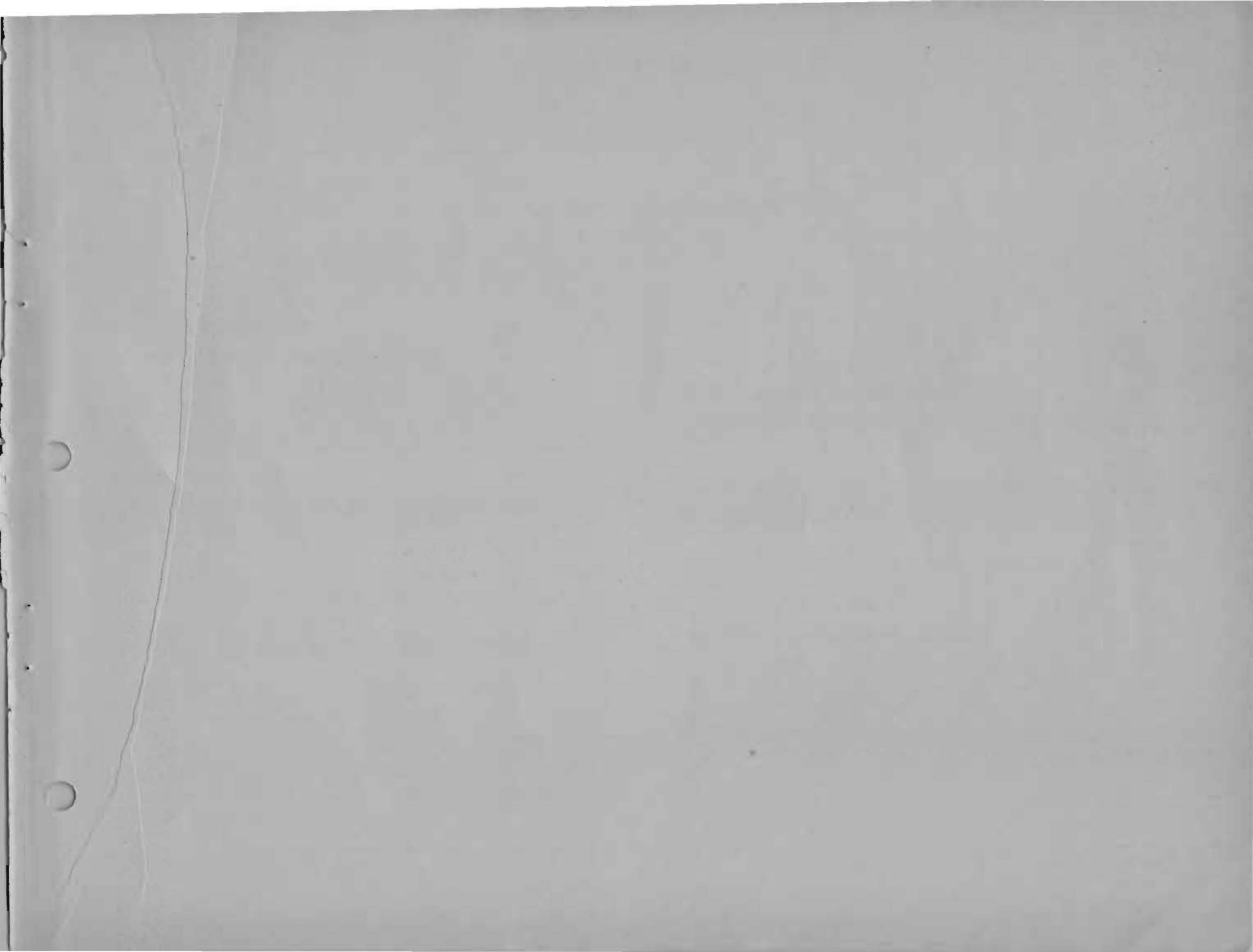

Block, TNT, 1/2-Pound

31.01

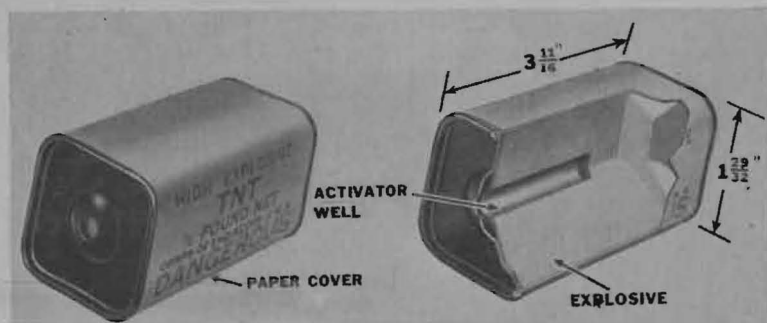

USE

As main charge or booster for larger charge for general demolition purposes. Relatively insensitive to shock and small-arms fire. Usable under water.

DESCRIPTION

Half-pound block of compressed TNT of 1.46 density enclosed in olive drab cardboard container with lacquered metal ends. Activator well provided which is not threaded.

CONNECTING ITEMS

Detonated by Cap, Blasting, Special Electric (11.02) held in place by Adaptor, Priming (42.40).

Detonated by Cap, Blasting, Special Nonelectric (11.01) held in place by Adaptor, Priming (42.40), and crimped onto Fuse, Blasting, Time (12.01).

Detonated by Cap, Blasting, Special Nonelectric (11.01) crimped onto a standard coupling base of any firing device.

REFERENCES

FM 5-25 p. 3; TM 9-1940 p. 36; OCL A51-43

Block, TNT, 1-Pound

31.02

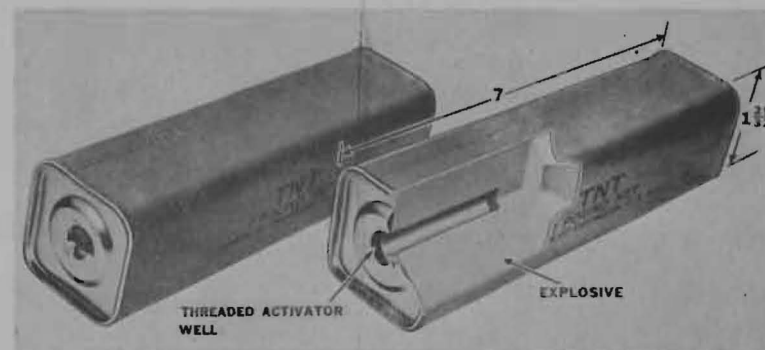

USE

As main charge or booster for larger charge for general demolition purposes. Relatively insensitive to shock and small-arms fire. Usable under water.

DESCRIPTION

Compressed TNT of 1.46 density enclosed in olive drab cardboard container with lacquered metal ends. Standard threaded activator well provided. Container can be cut to provide two half pound blocks of compressed TNT each bare and with a bare activator well.

CONNECTING ITEMS

Detonated by Cap, Blasting, Special Electric (11.02) held in place by Adaptor, Priming, (42.40).

Detonated by Cap, Blasting, Special Nonelectric (11.01) held in place by Adaptor Priming (42.40), and crimped onto Fuse, Blasting, Time (12.01).

Detonated by Cap, Blasting, Special Nonelectric (11.01) crimped onto a standard coupling base of any firing device.

REFERENCES

FM 5-25 p. 3

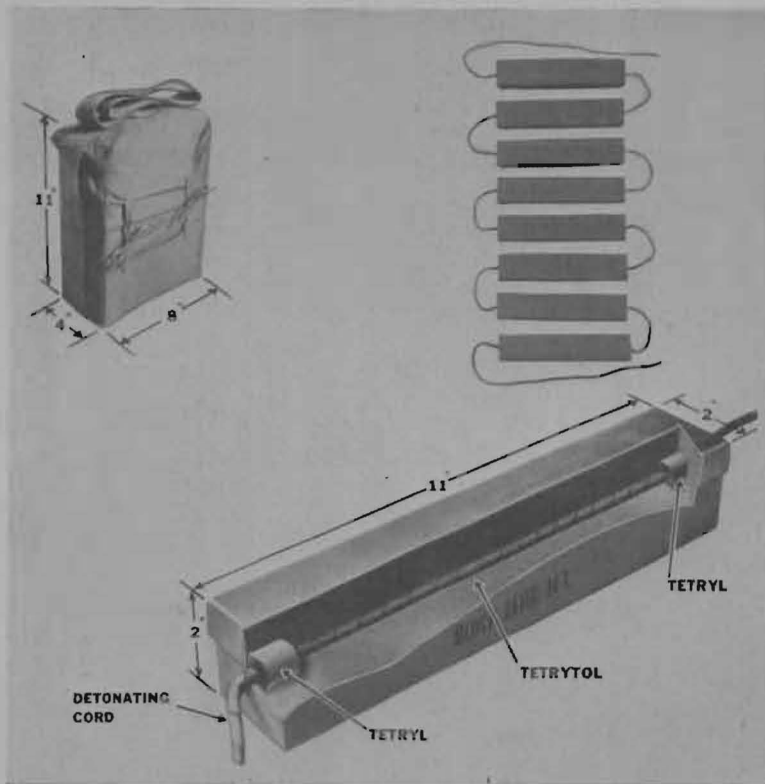

USE

General demolition purposes. More effective than compressed TNT as cutting or breaching charge. Chain of eight blocks provides flexibility in arranging charges. Blocks may be cut apart for individual use. Usable under water.

DESCRIPTION

2.5 pound tetrytol block with tetryl boosters in each end, wrapped in olive drab waterproof paper. Eight blocks cast eight inches apart on detonating cord. Two feet of detonating cord at each end of chain. Supplied in olive drab cloth haversack as shown.

CONNECTING ITEMS

Detonated by Cap, Blasting, Special Electric (11.02) or Cap, Blasting, Special Nonelectric (11.01) properly attached to detonating cord.

REFERENCES

FM 5-25 p. 6; TM 9-1940 p. 33-36

USE

General demolition purposes. More effective than compressed TNT as cutting or breaching charge. Single blocks each with a standard threaded activator well. Usable under water. No Navy stocks available but Army stocks available for Navy stock procurement (p. 10).

DESCRIPTION

2.5 pound tetrytol blocks with tetryl booster in both ends around the threaded cap wells. Supplied in olive drab cloth haversack as shown.

CONNECTING ITEMS

Detonated by Cap, Blasting, Special Electric (11.02) held in place by Adaptor, Priming (42.40).

Detonated by Cap, Blasting, Special, Nonelectric (11.01) held in place by Adaptor, Priming (42.40) and crimped onto Fuse, Blasting, Time (12.01).

Detonated by Cap, Blasting, Special Nonelectric (11.01) crimped onto any firing device with standard coupling base.

Detonated by Fuze, Detonating, Hand Grenade, M6A1 (16.10) screwed into activator well.

REFERENCES

FM 5-25 p. 6; TM 9-1940 p. 33-36

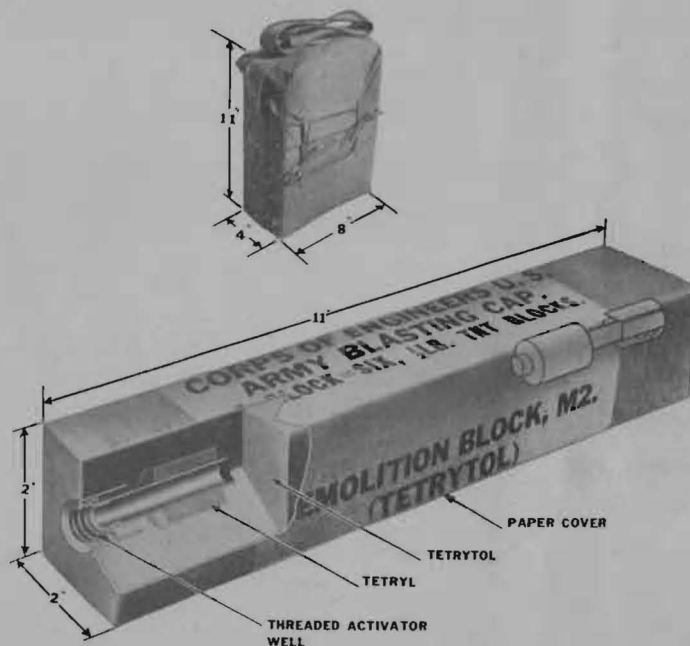

Block, Demolition, M3

31.05

USE

Bulk plastic explosive (Composition C-2 or C-3), 25% more powerful than TNT. Molded in place by hand, usable under water. Not at present on ships allowance lists because during long stowage plastic qualities may be lost, and some deterioration and exudation may occur (p. 10).

DESCRIPTION

Dark brown putty-like material, plastic between -20°F. and $+125^{\circ}\text{F.}$, furnished in $2\frac{1}{4}$ lb. blocks wrapped in glazed paper and enclosed in cardboard cartons. Eight blocks packed in haversack.

CONNECTING ITEMS

Detonated by Cap, Blasting, Special Electric (11.02), Cap, Blasting, Special Nonelectric (11.01) or Cord, Detonating, (17.01, 17.02, 17.03) when used according to approved techniques. An overhand knot must be tied in the detonating cord to insure detonation.

REFERENCES

FM 5-25 p. 8

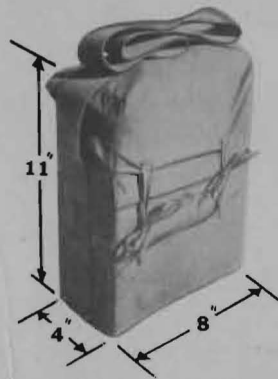

Block, Demolition, M4

31.06

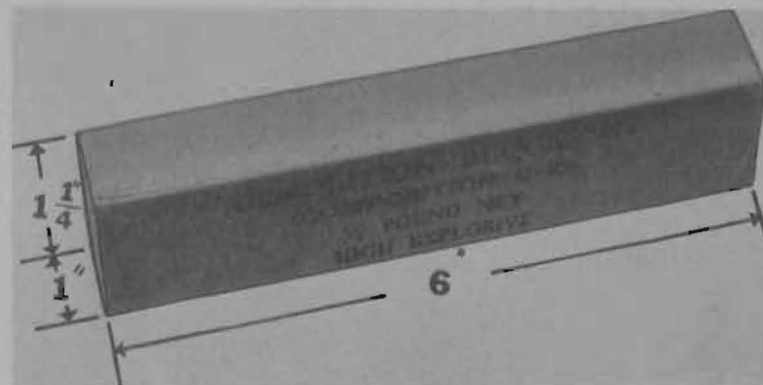

USE

Bulk plastic explosive (composition C-2 or C-3), 25% more powerful than TNT. Molded in place by hand, usable under water. No longer issued: Demolition Block M3 (31.05) supplied instead.

DESCRIPTION

Dark brown putty-like material, plastic between -20°F. and $+125^{\circ}\text{F.}$, furnished in $\frac{1}{2}$ lb. blocks wrapped in glazed paper and enclosed in cardboard cartons.

CONNECTING ITEMS

Detonated by Cap, Blasting, Special Electric (11.02), Cap, Blasting, Special Nonelectric (11.01), or Cord, Detonating (17.01, 17.02, 17.03), when used according to approved techniques. An overhand knot must be tied in the detonating cord to insure detonation.

REFERENCES

FM 5-25, p. 9

RESTRICTED

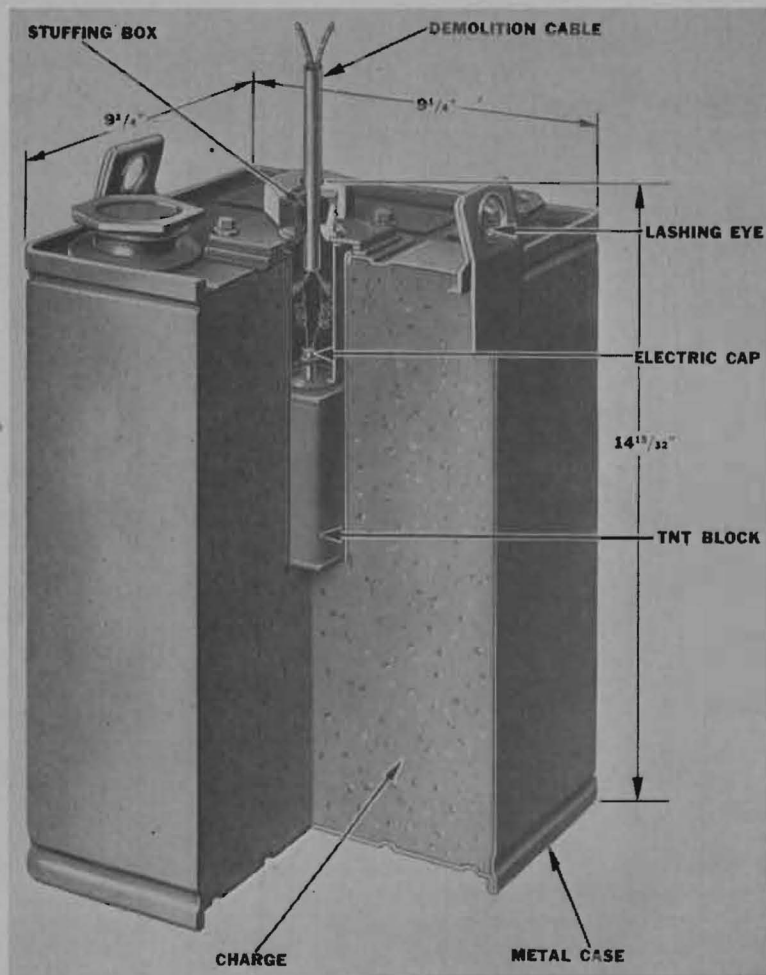
**USE**

55 lb. general purpose waterproof demolition charge designed for electrical firing in air or in water encountered in clearing wrecks.

DESCRIPTION

Rustproof steel case containing approximately 55 pounds cast TNT with half pound TNT Block (31.01) as booster. Constructed as shown with gaskets and packing gland for fitting around demolition cable of .330 to .350 inch diameter. Cable, Demolition, Double Conductor (41.04) or other like diameter cable is required to fit the packing gland but is not furnished as part of the charge. Lashing eyes absent in earlier issue.

CONNECTING ITEMS

Detonated by Cap, Blasting, Special Electric (11.02) attached to the required length of Cable, Demolition Double Conductor (41.04).

REFERENCES

OP 1012

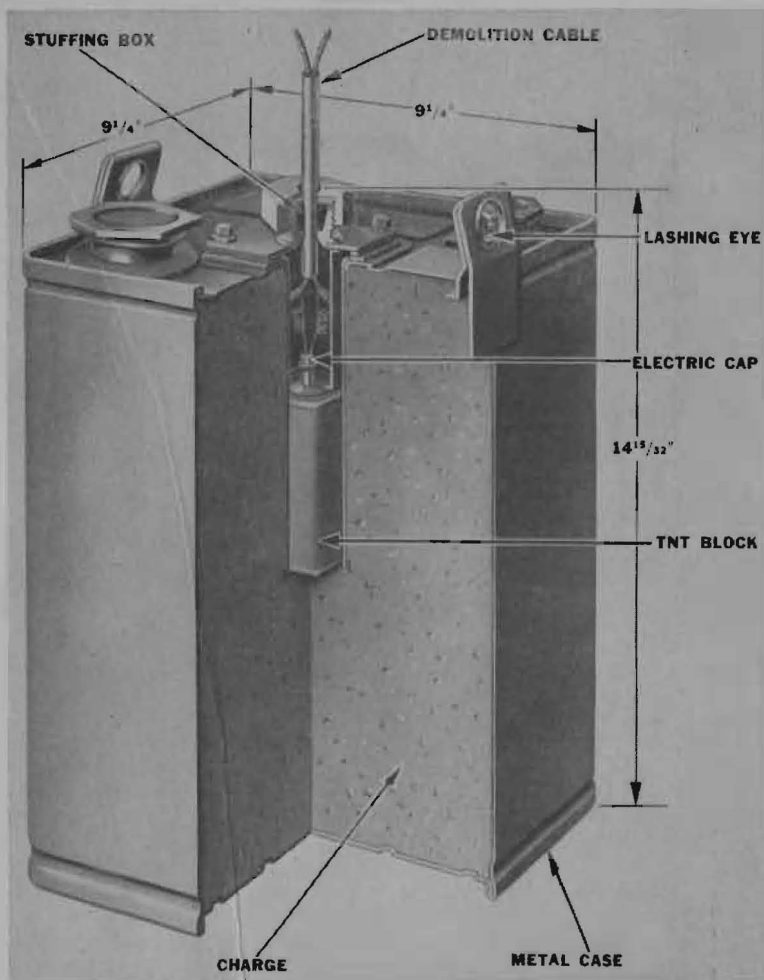

USE

55 lb. general purpose waterproof demolition charge, arranged for mechanical or electrical firing in air or in water.

DESCRIPTION

Rustproofed steel case containing approximately 55 Pounds of

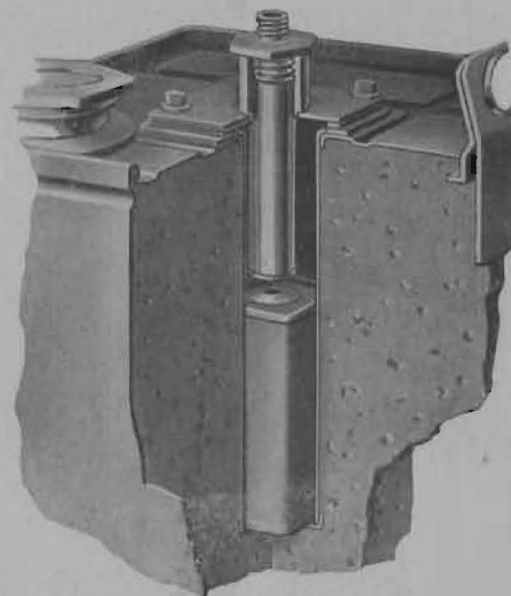

WITH BOOSTER MARK 13 MOD 0

Cast TNT, with ½ lb. TNT block (31.01) as booster. Assembled with inert fittings for electrical firing, and shipped with added inert parts for mechanical firing which can be assembled as shown. Charge Mark 2 Mod. 0 (earlier issue), includes only parts for electrical firing. For electrical firing, the packing gland requires a cable of .330 to .350 inch diameter such as Cable, Demolition, Double Conductor (41.04). For mechanical firing with parts firmly attached, Booster Mark 13 Mod. 0 (22.05) is required in addition to the half pound block furnished as a booster for the main charge.

CONNECTING ITEMS

Detonated electrically by Cap, Blasting, Special Electric (11.02) attached to the required length of Cable, Demolition, Double Conductor (41.04) and assembled as shown.

Detonated mechanically by Booster Mark 13 Mod. 0 (22.05) with Cap, Blasting, Special Nonelectric (11.01) and any standard mechanical firing device having standard striker case thread.

REFERENCES

OP 1012

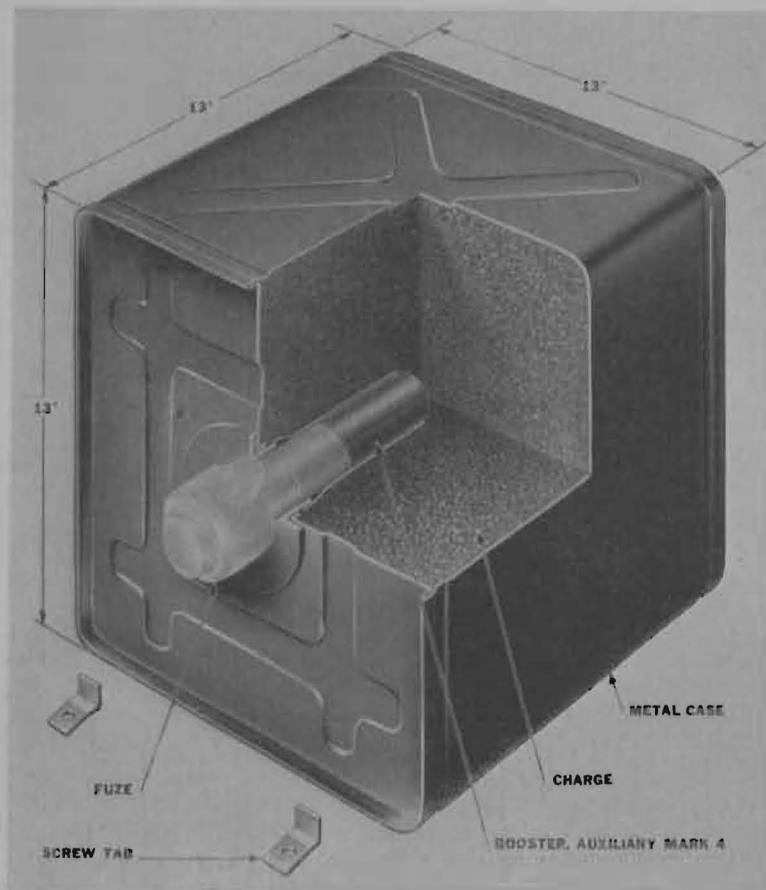

USE

115 lb. general purpose waterproof demolition charge for use with standard 1 $\frac{3}{4}$ " bomb nose fuzes. Component of Demolition Outfits Mark 114 Mod. 0 and Mark 118 Mod. 0 which outfits are reserved for special programs.

DESCRIPTION

Rustproofed steel case containing approximately 115 pounds cast TNT. Fitted with standard 1 $\frac{3}{4}$ " bomb nose fuze seat and fuze seat liner in which is carried Auxiliary Booster Mark 4 Mod. 0 (63 grams of granular TNT in a paper container with metal ends); held in place for shipment by cardboard spacer and gasketed shipping plug (not shown). Four brackets and four mounting screws are furnished.

CONNECTING ITEMS

Designed for detonation by Fuze, Mark 143 Mod. 0 (21.02) or Fuze, Mark 143 Mod. 1 (21.03).

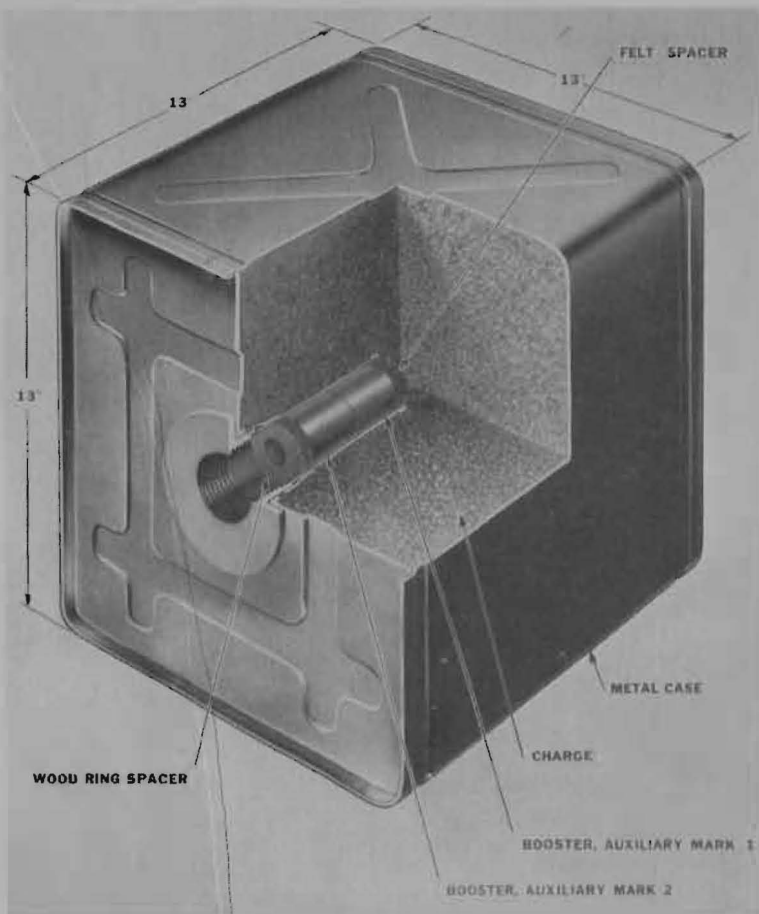

USE

115 lb. general purpose waterproof demolition charge for use with standard bomb nose fuzes. Component of Demolition Outfits Mark 114 Mod. 0 and Mark 118 Mod. 0 which outfits are reserved for special programs.

DESCRIPTION

Rustproof steel case containing approximately 115 pounds cast TNT. Equipped with standard 2" bomb nose fuze seat and fuze seat liner, containing felt spacer, Auxiliary Boosters Mark 1 Mod. 0 and Mark 2, Mod. 0, and wood ring spacer; held in place for shipment by adapter and shipping plug (not shown).

Adapter provided for use with 1 3/4" bomb nose fuzes. Auxiliary Booster Mark 1 Mod. 0 contains 180 grams of granular TNT in a copper container, and Auxiliary Booster Mark 2 Mod. 0 contains 120 grams of granular TNT in a copper container. Only shipping plug removed and entire contents of fuze seat liner left in place when fuzes Mark 143 Mod. 0 or Mod. 1 are used. No brackets or mounting screws are furnished.

CONNECTING ITEMS

Designed for detonation by Fuze Mark 143 Mod. 0 (21.02) Fuze Mark 143 Mod. 0 (21.01) or certain other fuzes having 2 inch or 1 3/4 inch diameter fuze seats.

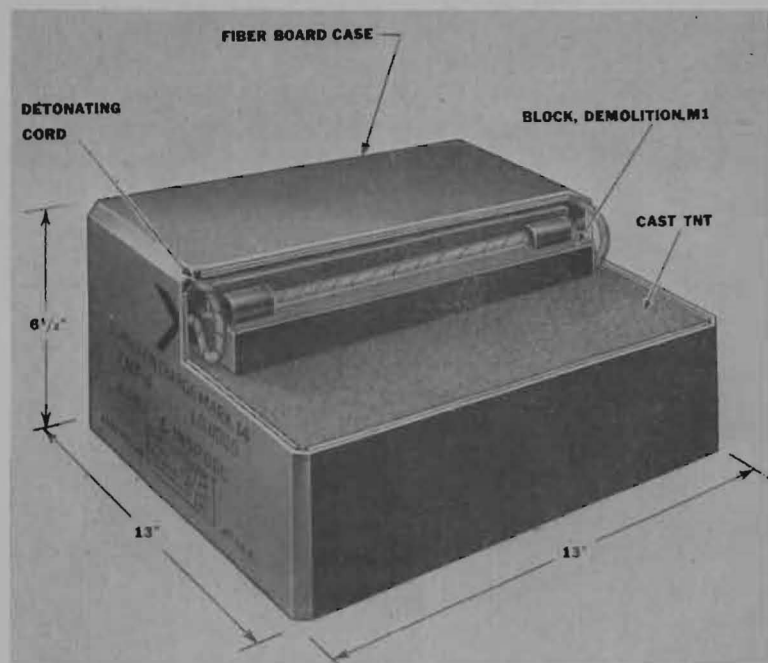
**USE**

50 lb. general purpose water-resistant charge. Designed for sympathetic detonation. Can be directly fired from self-contained detonating cord. Component Demolition Outfits Mark 114 Mod. 0 and Mark 118 Mod. 0 which are reserved for special programs.

DESCRIPTION

Fiberboard case containing approximately 46 pounds of cast TNT, including in it a 2.5 pound tetrytol block cut from Block, Demolition, Chain, M1 (31.03) for boosting purposes.

CONNECTING ITEMS

Charge is primarily for sympathetic detonation, but may be fired by opening case, pulling out detonating cord and attaching properly to a blasting cap.

USE

50 lb. general purpose water resistant charge. Designed for sympathetic detonation. Component of Demolition Outfits Mark 114 Mod. 0 and Mark 118 Mod. 0, which are reserved for special programs.

DESCRIPTION

Fiberboard case containing approximately 49 pounds cast TNT.

CONNECTING ITEMS

Designed to be fired by sympathetic detonation from adjacent primed charges.

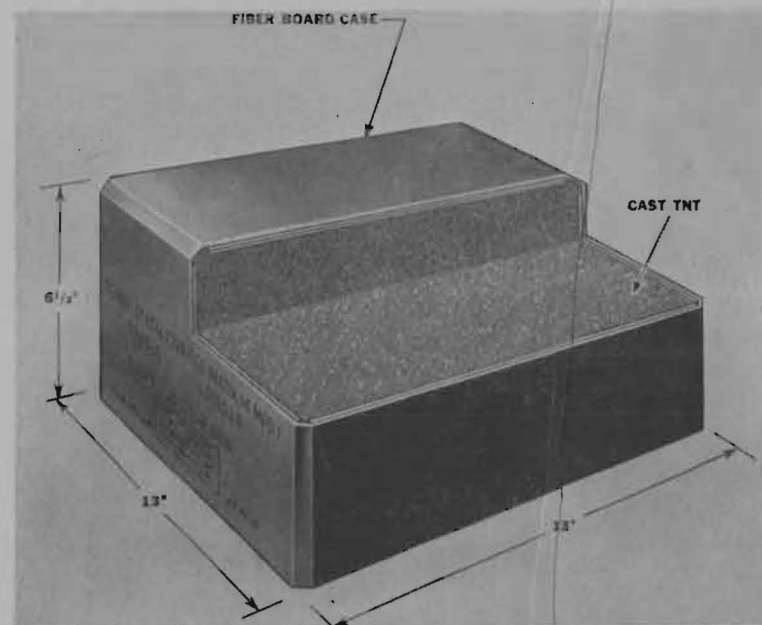

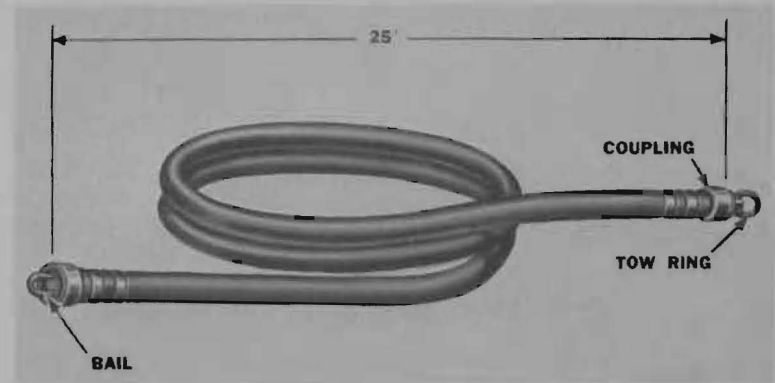
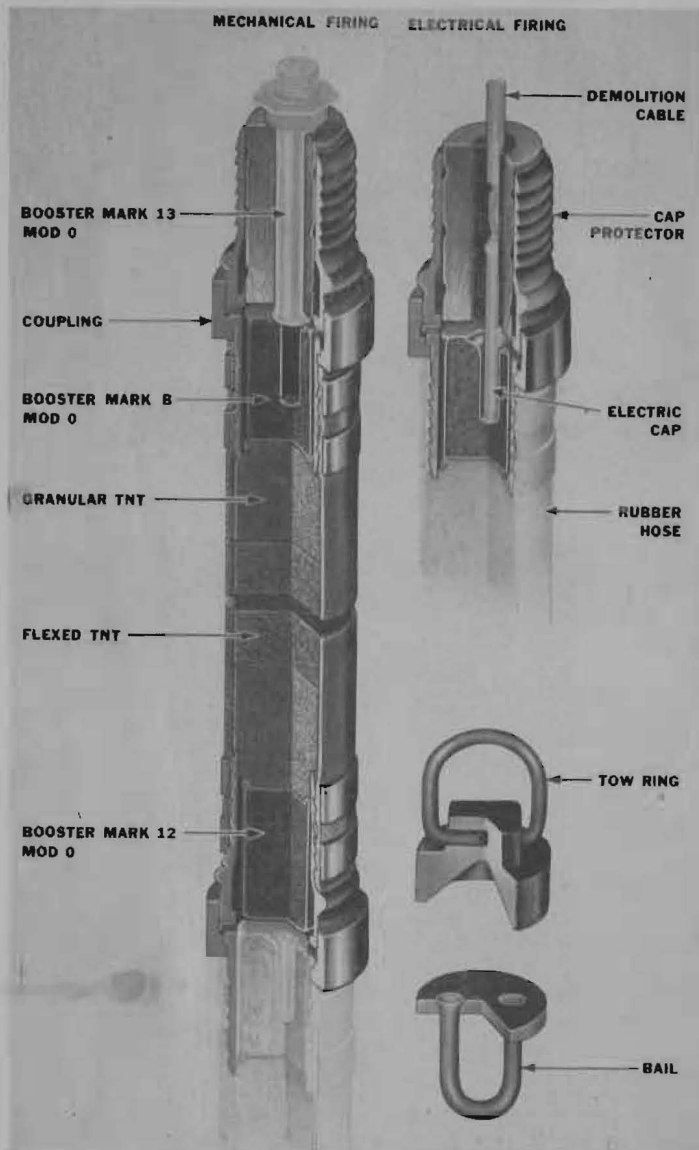

USE

Waterproof flexible hose charge for clearing paths and for lashing to or wrapping around obstacles. Additional lengths can be attached as required. Arranged for mechanical or electrical firing.

DESCRIPTION

25 ft. length of 2 inch rubber hose containing 50 pounds of flexed TNT. Each length contains one Booster Mark 8 Mod. 0 and one Booster Mark 12 Mod. 0 (76 and 79 grams of granular TNT in metal cans). Standard hose couplings at each end provided for attaching extra lengths. Each hose provided with towing fittings as shown. One cap protector assembly is furnished with every four charges.

CONNECTING ITEMS

Fired electrically by Cap. Blasting, Special Electric (11.02), assembled as shown.

Fired mechanically by Booster Mark 13 Mod. 0 (22.05) with Cap. Blasting, Special Nonelectric (11.01) and any firing device that will actuate the Booster Mark 13 Mod. 0.

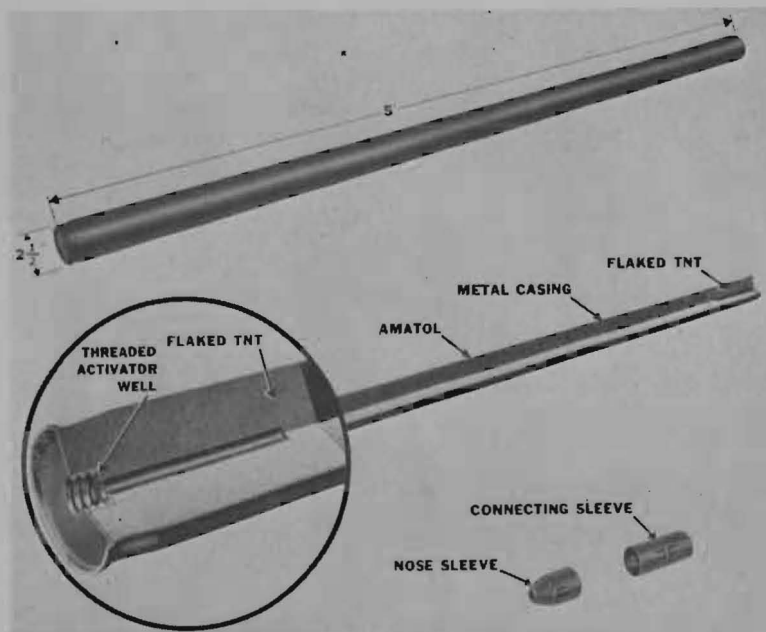

USE

For clearing paths through wire and mine fields, and for other demolition where its shape is advantageous. Additional lengths can be attached as required. For nonelectric or electrical firing.

DESCRIPTION

Five foot metal tube containing approximately 9½ pounds of 80/20 Amatol with 4 inches of TNT and threaded activator wells at both ends. Furnished in Kit containing 10 lengths, 10 connecting sleeves, and one nose sleeve.

CONNECTING ITEMS

Detonated by Cap. Blasting, Special Electric (11.02) held in place by Adaptor, Priming (42.40).

Detonated by Cap. Blasting Special Nonelectric (11.01) held in place by Adaptor, Priming (42.40) and crimped onto Fuse, Blasting, Time (12.01).

Detonated by Cap. Blasting, Special Nonelectric (11.01) crimped onto a standard coupling base of firing device.

REFERENCES

FM 5-30 p. 21, p. 75; FM 5-25 p. 15; TM 9-1940 p. 32; TB Eng 8 p. 16; TB 1900-5; TB 1940-2

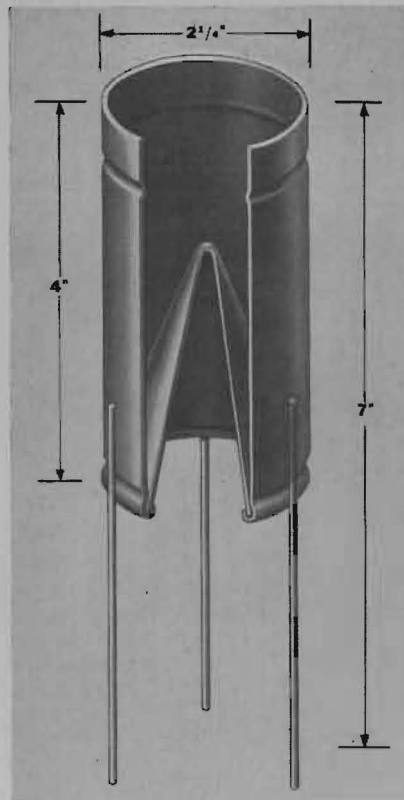

USE

Primarily for bomb disposal and mine disposal units (p. 10). Can be used for cutting and penetrating obstacles in air.

DESCRIPTION

Two inch steel cone in open top can with three wire legs providing proper standoff.

CONNECTING ITEMS

To be filled in field with approximately 3/8 lb. of plastic explosive (Composition C) (31.05) or (31.06).

Detonated by Cap, Blasting, Special Electric, (11.02) or Cap, Blasting Special Nonelectric (11.01).

REFERENCES

OP 1203 p. 7

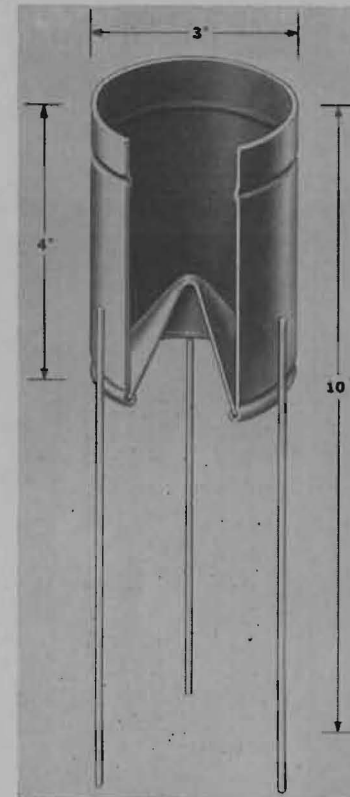

USE

Primarily for bomb disposal and mine disposal units (p. 10). Can be used for cutting and penetrating obstacles in air.

DESCRIPTION

Three inch steel cone in open top can with three wire legs providing proper standoff.

CONNECTING ITEMS

Detonated by Cap, Blasting, Special Electric (11.02) or Cap, Blasting, Special Nonelectric (11.01).

To be filled in field with approximately 1 1/2 lbs. of plastic explosive, Composition C (31.05) or (31.06).

REFERENCES

OP 1203 p. 11

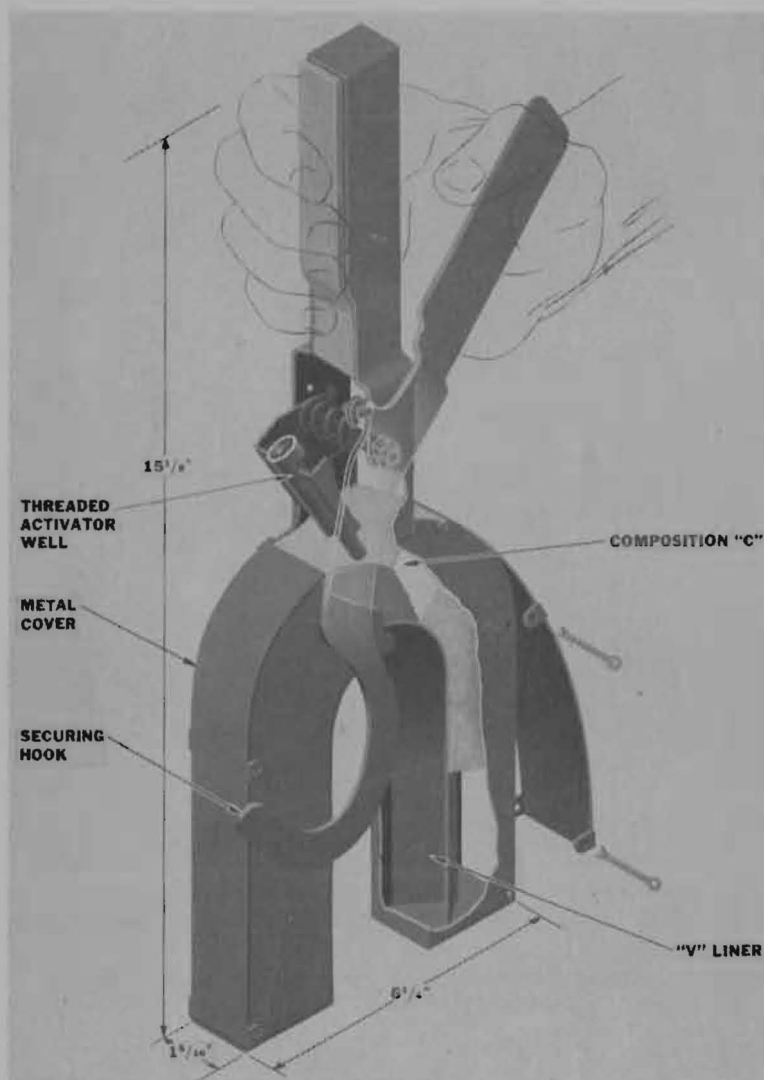

USE

Severs steel cable up to 2 inches diameter and anchor chain up to 1 inch. Designed for use in air or under water and for detonation by electrical or mechanical means. Will withstand depths of water as great as 20 feet.

DESCRIPTION

Steel U-shaped case with removable covers and watertight linear cavity charge liner constructed as shown. Standard threaded activator well provided for detonation of Composition C (to be packed in place of field). Spring clamping arm on handle secures charge on cable or chain link. Securing hooks (not shown) provided for firing wire.

CONNECTING ITEMS

To be filled in the field with approximately two pounds of plastic explosive, Composition C (31.05 or 31.06).

Detonated by Cap, Blasting, Special Electric (11.02) held in place by Adaptor, Priming (42.40).

Detonated by Cap, Blasting, Special Nonelectric (11.01) held in place by Adaptor, Priming (42.40) and crimped onto Fuse, Blasting, Time (12.01).

Detonated by Cap, Blasting, Special Nonelectric (11.01) crimped onto any standard coupling base.

REFERENCES

OTT M5-44

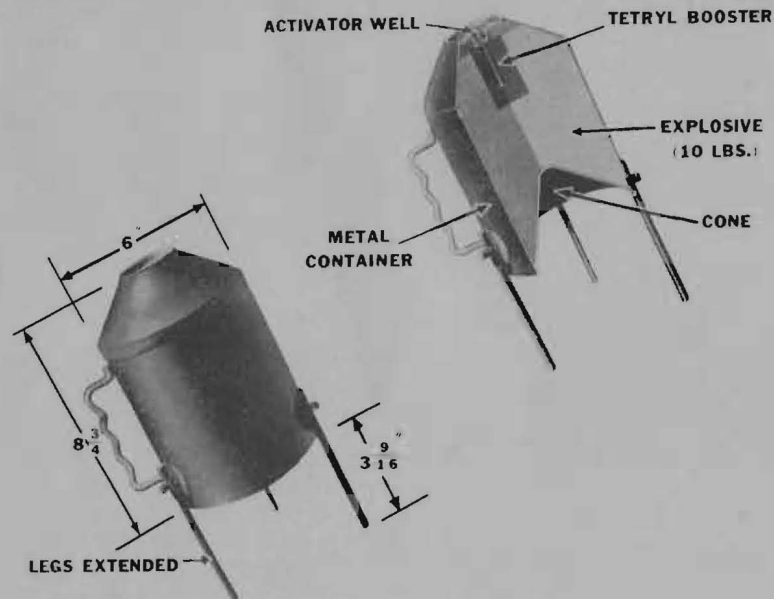
**USE**

Cutting and penetrating obstacles in air.

Will penetrate armor plate to depth of 8 inches, with diameter of hole tapering from approximately 3 inches to 2 inches.

Will penetrate reinforced concrete to depth of 30 inches, with diameter of hole tapering from approximately 3 inches to 2 inches.

DESCRIPTION

Six inch steel cone with 10 lb. TNT charge in steel case fitted with standard threaded activator well and metal handling strap. Detachable, adjustable steel legs on sides to provide proper standoff. This charge is now obsolete, substitute Charge, Shaped, M2.

CONNECTING ITEMS

Detonated by Cap, Blasting, Special Electric (11.02) held in place by Adaptor, Priming (42.40).

Detonated by Cap, Blasting, Special Nonelectric (11.01) held in place by Adaptor, Priming (42.40) and crimped onto Fuse, Blasting, Time (12.01).

Detonated by Cap, Blasting, Special Nonelectric (11.01) crimped onto any standard coupling base.

REFERENCES

FM 5-25, p. 13

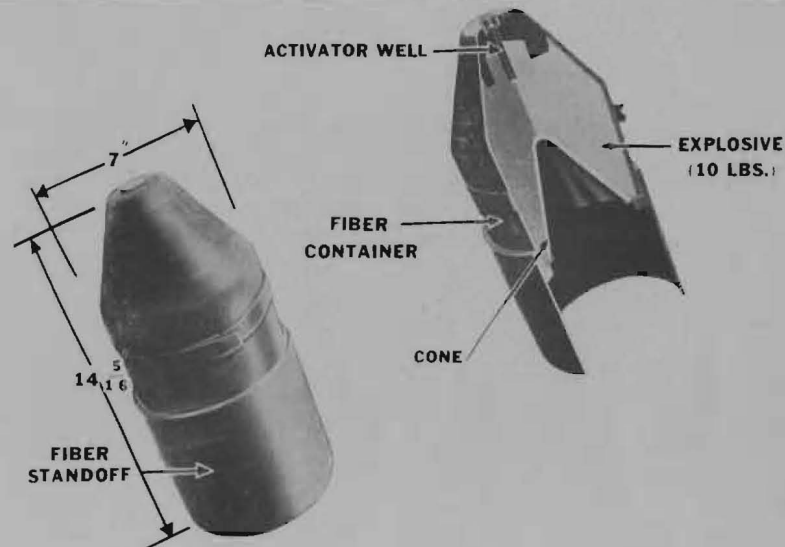
**USE**

Cutting and penetrating obstacles in air.

Will penetrate armor plate to depth of 12 inches, with diameter of hole tapering from approximately 3 1/2 inches to 2 inches.

Will penetrate reinforced concrete to depth of 32 inches with diameter of hole tapering from approximately 3 1/2 inches to 2 inches.

DESCRIPTION

Six inch cone with 10 lb. Pentolite charge in weatherproof fiber case providing proper stand-off. Standard threaded activator well. Fabric handling strap.

CONNECTING ITEMS

Detonated by Cap, Blasting, Special Electric (11.02) held in place by Adaptor, Priming (42.40).

Detonated by Cap, Blasting, Special Nonelectric (11.01) held in place by Adaptor, Priming (42.40) and crimped onto Fuse, Blasting, Time (12.01).

Detonated by Cap, Blasting, Special Nonelectric (11.01) crimped onto any standard coupling base.

REFERENCES

FM 5-25 p. 13-14

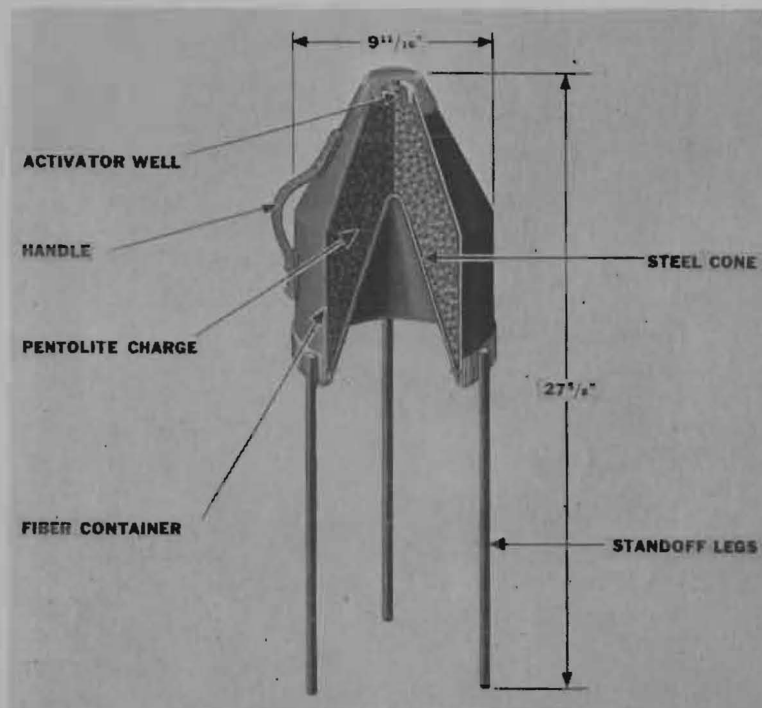

USE

Cutting and penetrating obstacles in air.

Will penetrate reinforced concrete to depth of 55 inches with diameter of hole tapering from approximately 5 inches to 1 3/4 inches. In concrete, the hole produced usually permits Bangalore Torpedo (33.20) to be inserted a distance of 27 to 40 inches.

DESCRIPTION

9.5 inch steel cone with 26 pound Pentolite charge in weatherproof, molded fiber case. Detachable steel legs provide proper standoff. Fitted with standard threaded activator well and fabric webbing handling strap. Earlier designation was Charge, Shaped, T3.

CONNECTING ITEMS

Detonated by Cap, Blasting, Special Electric (11.02) held in place by Adaptor, Priming (42.40).

Detonated by Cap, Blasting, Special Nonelectric (11.01) held in place by Adaptor, Priming (42.40) and crimped onto Fuse, Blasting, Time (12.01).

Detonated by Cap, Blasting, Special Nonelectric (11.01) crimped onto a standard coupling base of any firing device.

Detonated by Detonator, 15 Second Delay, M1 (16.07) where such delay is appropriate.

REFERENCES

TB 1940-6

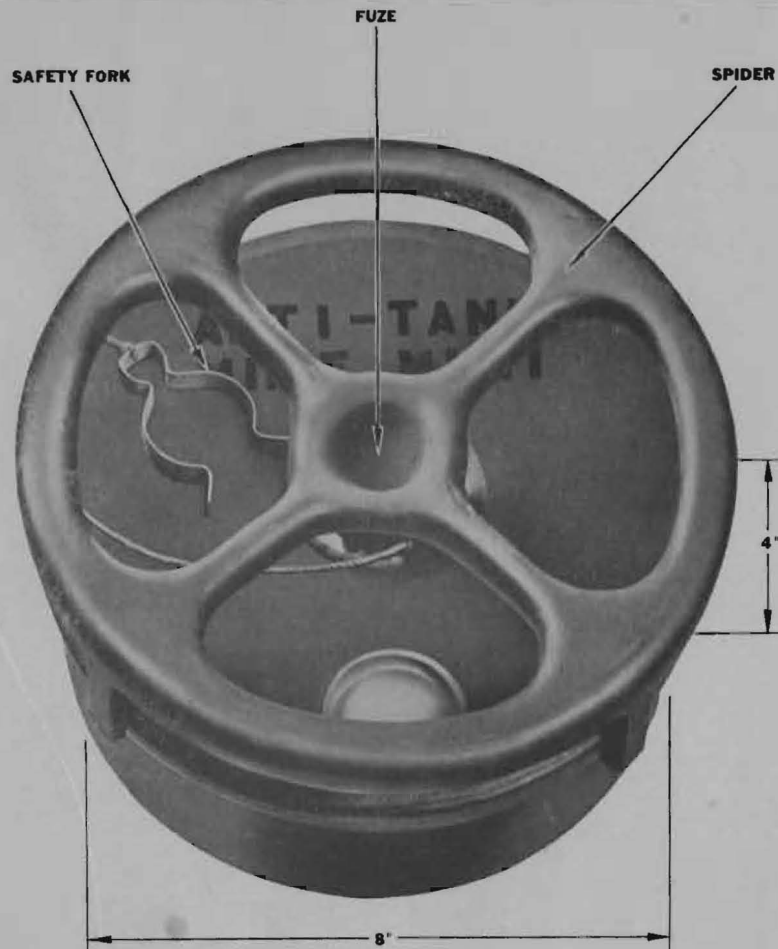

USE

Antivehicular mine, detonating on application of pressure of 250 pounds at edge to 500 pounds at center.

DESCRIPTION

Pressure on spider depresses fuze head, cuts shear pins, and aligns inner and outer sleeves so steel balls are forced into outer sleeves; releasing striker, which sets off percussion cap, booster, and 5½ pound cast TNT main charge. Constructed as shown of sheet steel.

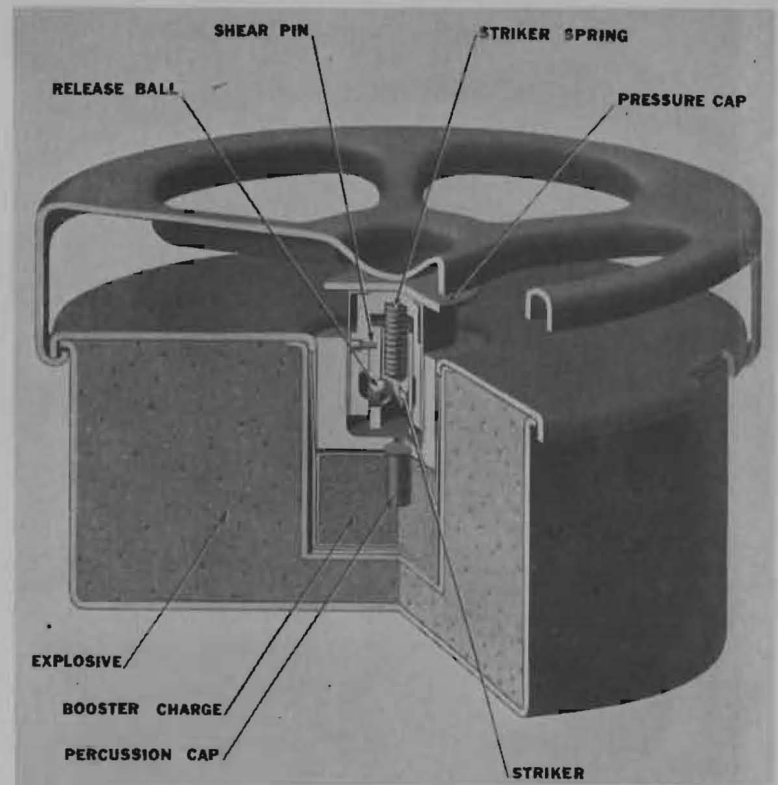

Furnished complete with Fuze, Mine, Antitank, H.E., M1A1 or M1A2 and Mine Cover.

CONNECTING ITEMS

None required for operation.

REFERENCES

FM 5-31 p. 51.01; FM 5-30 p. 9, p. 13, p. 15; TM 9-1940 p. 11

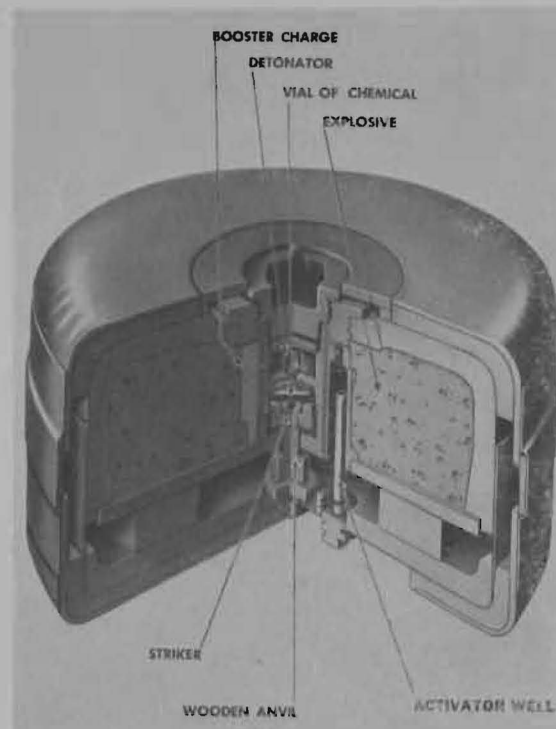
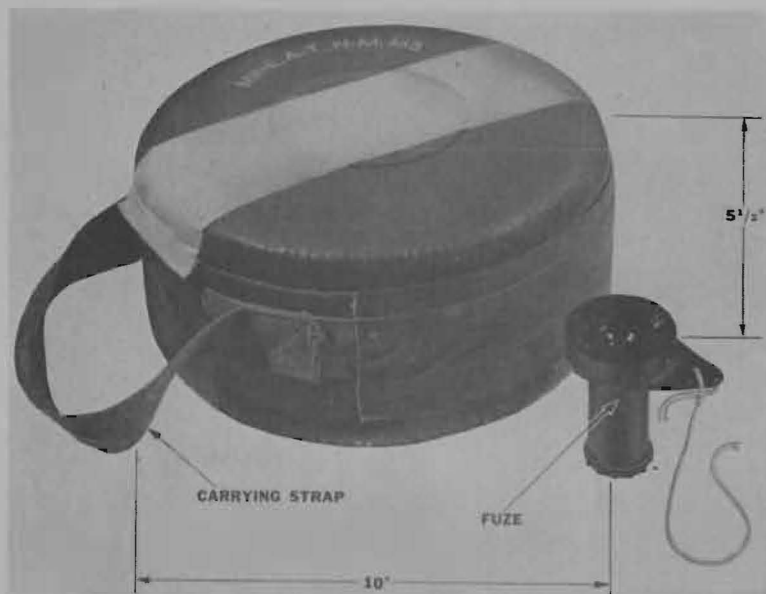

USE

Antivehicular mine, not detectable by standard magnetic mine locators. Detonates on application of 275 to 425 pounds pressure. Used with firing devices as antipersonnel or demolition charge.

DESCRIPTION

Pressure on cover crushes chemical vial; mixing chemicals which cause flash, setting off detonator, booster, and 5.6 pound TNT main charge. Constructed as shown of wood and nonmetallic plastics, with standard threaded activator well in bottom which accommodates nonelectric blasting caps crimped on any standard coupling base. Furnished complete with Fuze, Mine, Antitank, H.E., M5.

CONNECTING ITEMS

None required for operation as antitank mine.
Detonated by Cap, Blasting, Special Nonelectric (11.01) crimped onto a standard coupling base of any mechanical firing device.

REFERENCES

FM 5-31 p. 51.03; FM 5-30 p. 16-18; TM 9-1940 p. 20-21

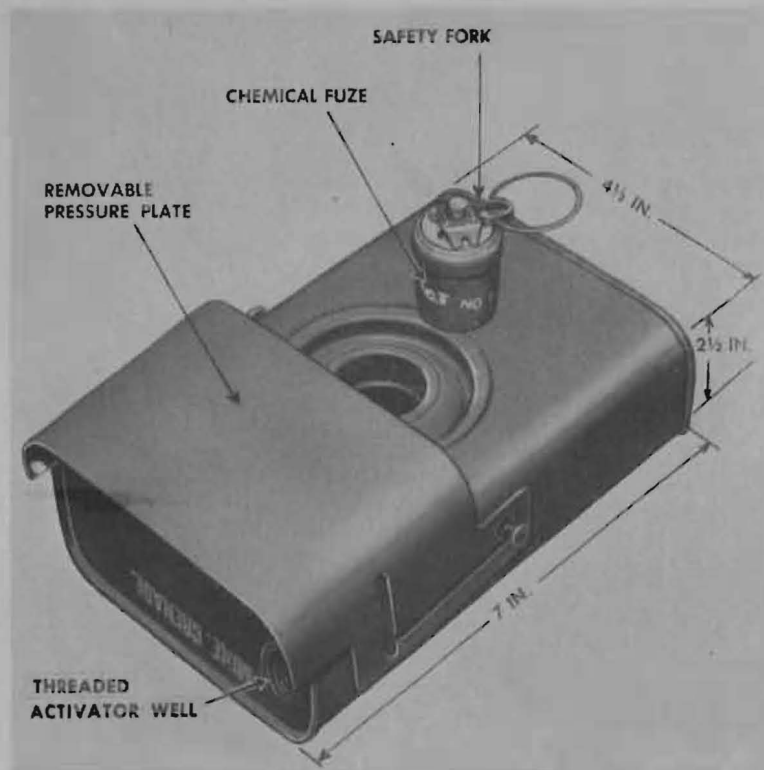

USE

Used as light antivehicular mine, detonating with application of 190 pounds pressure. Used as antipersonnel mine or demolition charge with standard firing devices. No Navy stocks but procurement can be initiated from Army (p. 10).

DESCRIPTION

Depressing pressure plate pushes striker down, breaking chemical vial and mixing chemicals which cause flash, setting off detonator, booster, and 3 1/4 lb. tetrytol main charge. Constructed as shown of light sheet metal with threaded activator well which accommodates

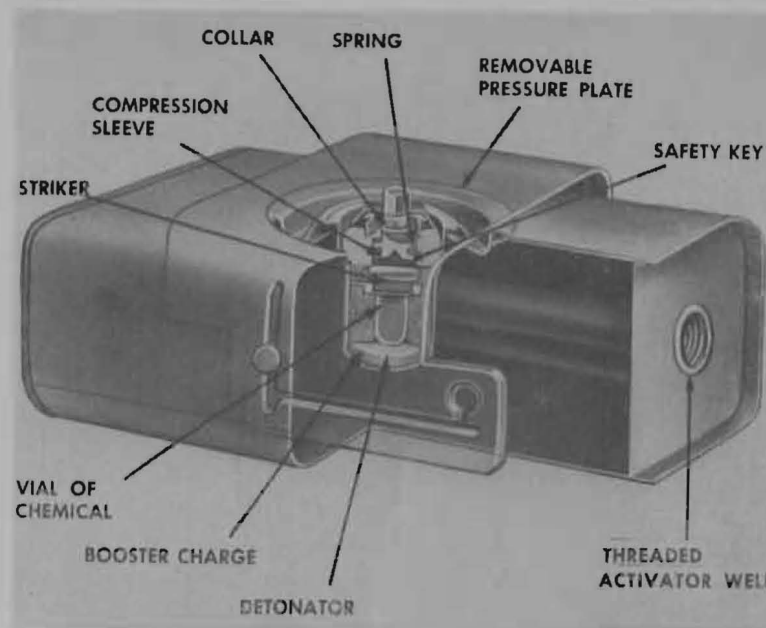

blasting cap and with standard threaded coupling base firing device. Furnished complete with Fuze, Chemical Antitank M 600. Earlier designation was Mine, H.E. Antitank, Light, T7; however, different fuzes were furnished under that designation.

CONNECTING ITEMS

None required for operation as antitank mine.

Detonated by Cap. Blasting, Special Nonelectric (11.01) crimped onto any standard coupling base.

REFERENCES

FM 5-31 p. 51.05; TB 9-1940-4

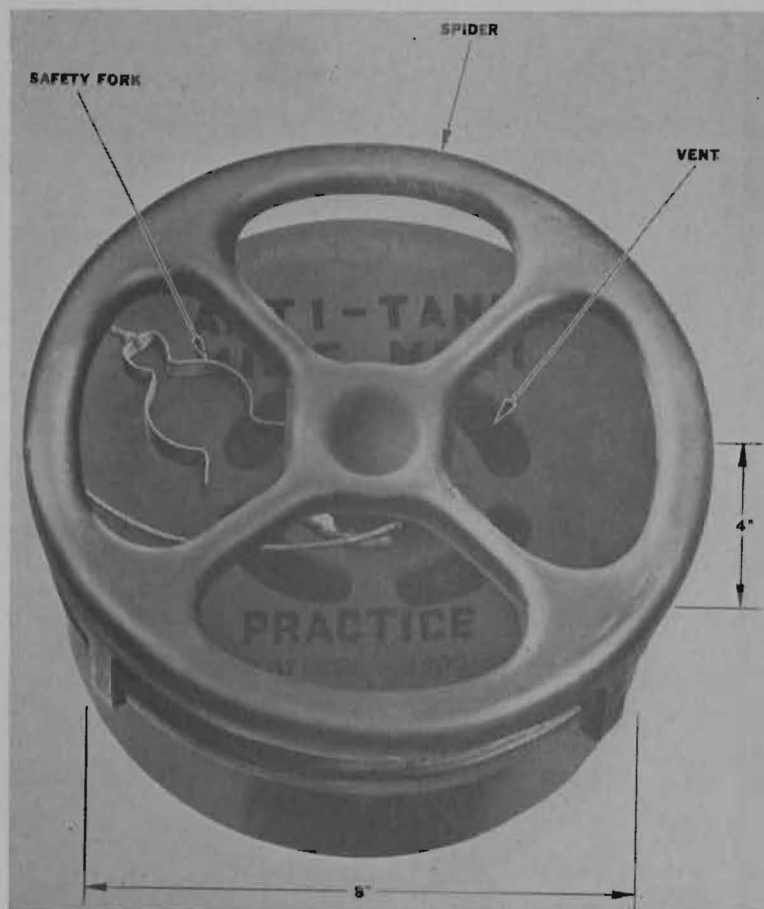

USE

Training device for practice mine fields, which detonates harmlessly with conspicuous smoke puff on application of from 250 to 500 pounds pressure.

DESCRIPTION

Pressure on spider cuts shear pin and aligns inner and outer sleeve, so steel balls are forced into outer sleeve; releasing striker.

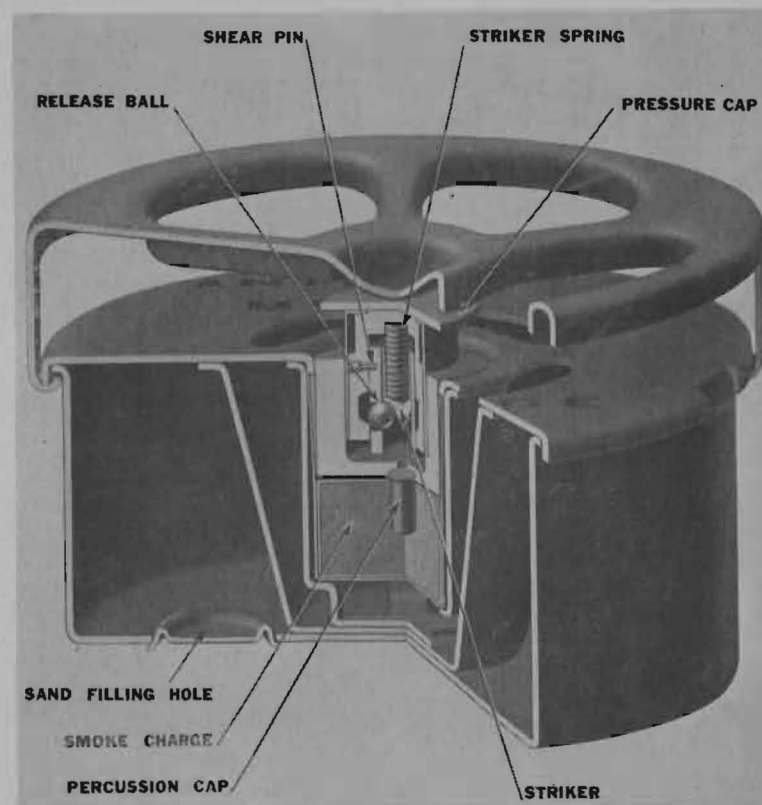

which sets off percussion cap and smoke puff charge. Constructed as shown of sheet steel with cast iron case which duplicates weight of TNT main charge in standard M1A1 mine. Furnished complete with Practice Fuze M1.

CONNECTING ITEMS

None required for operation.

REFERENCES

FM 5-30 p. 18; TM 9-1940 p. 14

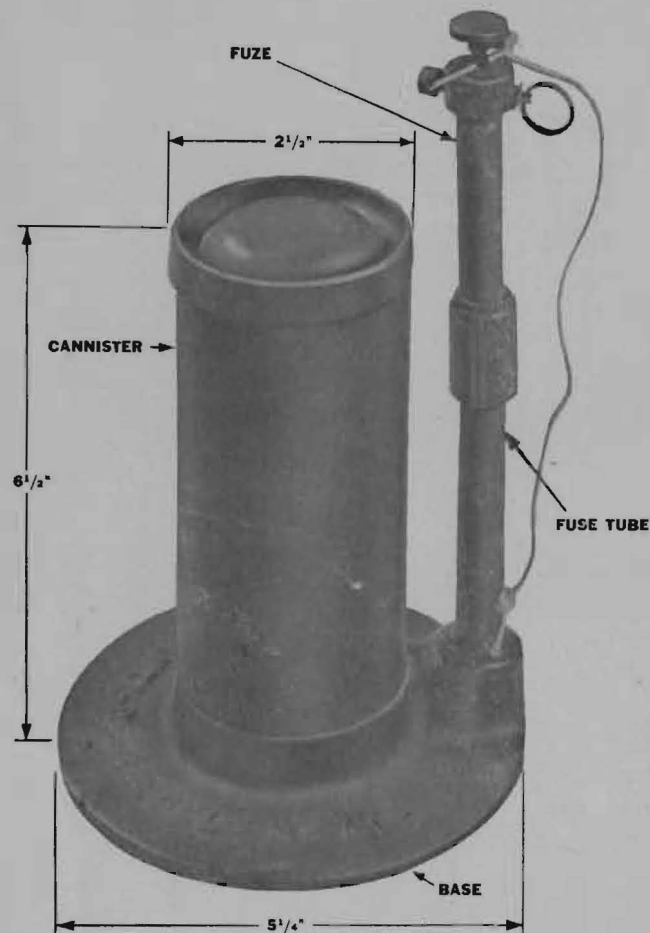

USE

Antipersonnel fragmentation mine propelled upward from concealed location, causing casualties to most personnel within 10 yards. Detonated by 20 to 40 pound pressure or 3 to 6 pound pull on trip wire.

DESCRIPTION

Pressure on cap or pull on ring releases striker, which fires percussion cap, flash igniter, and propelling charge; initiating delay fuze

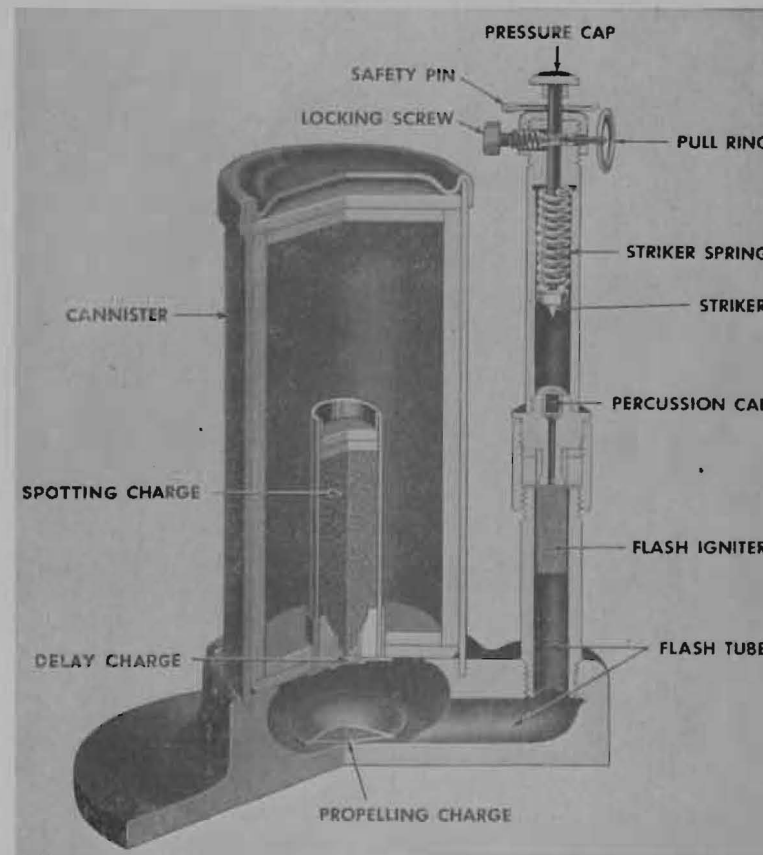

and projecting shell from tube. Delay fuze detonates 0.4 lb. TNT charge when shell is 6 to 8 feet from tube. Constructed of metal and furnished complete with Fuze, Mine, Antipersonnel, M2, M6, or M2A1 complete and with 1 spool containing 4 steel trip wires each 26 feet long.

CONNECTING ITEMS

None required for operation but standard coupling base provides for substitution of other mechanical firing devices.

REFERENCES

FM 5-31 p. 52.01; FM 5-30 p. 66-79; TM 9-1940 p. 23

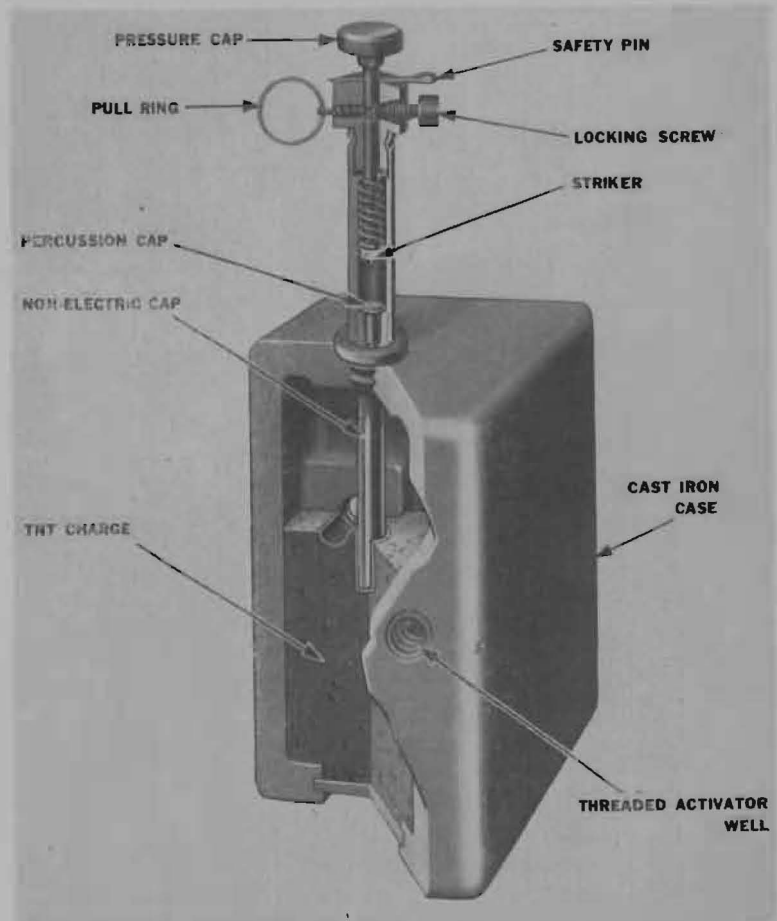
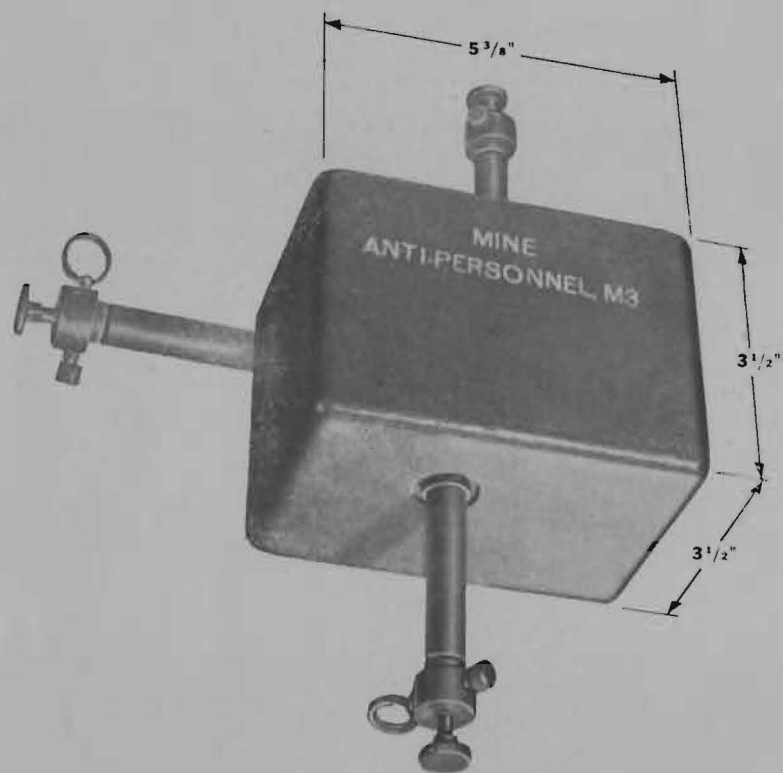

USE

Antipersonnel charge used primarily in booby traps. Detonated by 3 to 6 pound pull on trip wire or 20 to 40 pound pressure on cap. Can be fired by any firing device having standard cap chamber or base.

DESCRIPTION

Pull on ring or pressure on cap releases striker, firing percussion cap, nonelectric blasting cap, and 0.85 lb. flaked TNT charge. Cast iron case constructed as shown with three standard threaded activator wells. Unit package contains 6 Fuzes, Mine, Antipersonnel, M3, M7,

or M3A1 complete, each in fiber container; 6 spools each with 4 wires 26 feet long, and one wrench.

CONNECTING ITEMS

Cap, Blasting, Special Nonelectric (11.01) crimped onto fuze as shown or onto standard coupling base of any mechanical firing device.

REFERENCES

FM 5-31 p. 52.02; FM 5-30 p. 60-68; TM 9-1940 p. 23

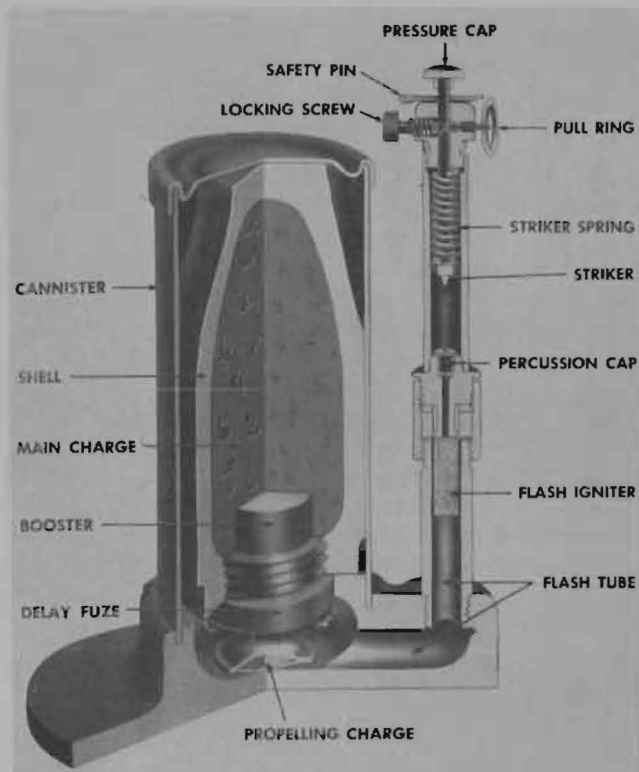

USE

Training device which replaces Antipersonnel Mine M2A1 (36.01) in practice booby traps. Harmless spotting charge detonates after application of 20 to 40 pounds pressure or 3 to 6 pounds pull on trip wire. No Navy stocks but procurement can be initiated from Army (p. 10).

DESCRIPTION

Pressure on cap or pull on ring releases striker, which fires percussion cap, flash igniter, and propelling charge; initiating delay charge and projecting spotting charge shell from tube. Delay charge detonates spotting charge when shell is six to eight feet from tube. Constructed of metal with cardboard spotting shell, furnished complete with fuze as shown. Unit package contains 6 mines, 6 fuzes, 2 projectors, and 20 sets replacement parts.

CONNECTING ITEMS

None required for operation but standard coupling base provides for substitution of other mechanical firing devices.

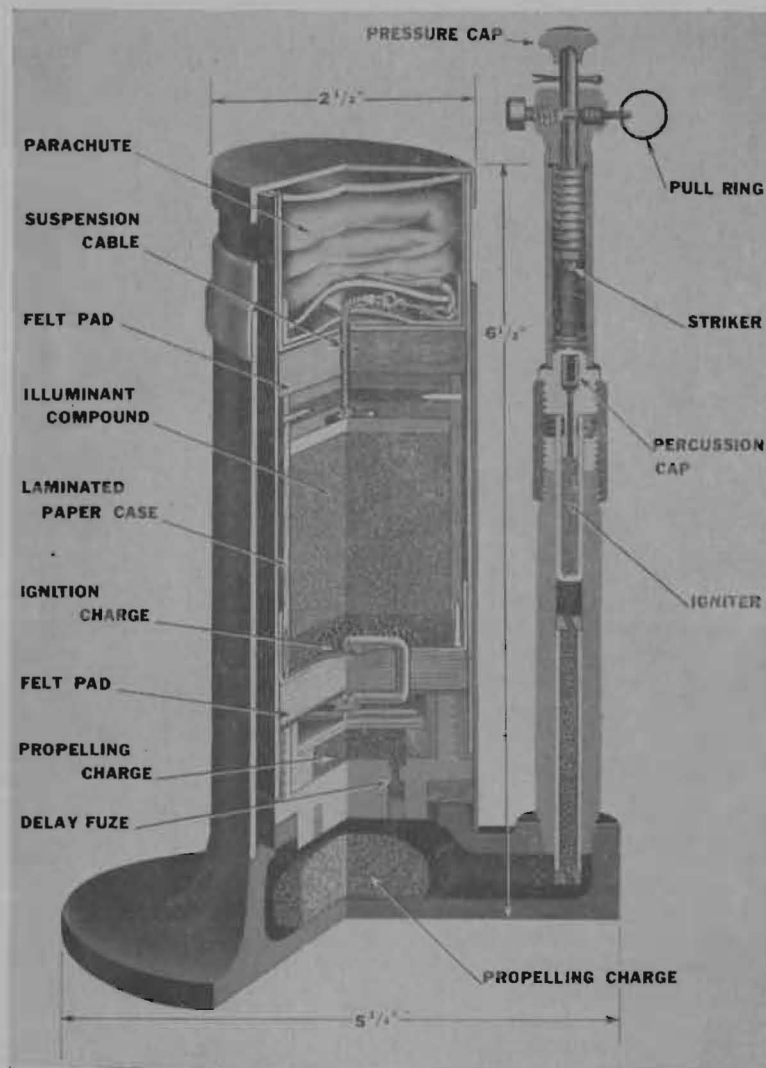

USE

Warning device in mine fields or other obstacle areas. Provides night illumination over 300 yard radius. Fires with 3 to 6 pound pull on trip wire or 20 to 40 pound pressure on cap.

DESCRIPTION

Pressure on cap or pull on ring releases striker, firing percussion cap, igniter, and propelling charge, which projects canister into the air and ignites delay fuze in its base. At height of 300 to 500 feet delay fuze sets off propelling charge; ejecting parachute, flare, and ignition charge. Parachute unfolds and ignition charge starts flare, which burns for 20 seconds. Constructed of steel as shown, furnished complete with Fuze M1, and spool of trip wire.

CONNECTING ITEMS

None required for operation. Firing devices may be substituted for fuze.

REFERENCES

FM 5-31 p. 54.01

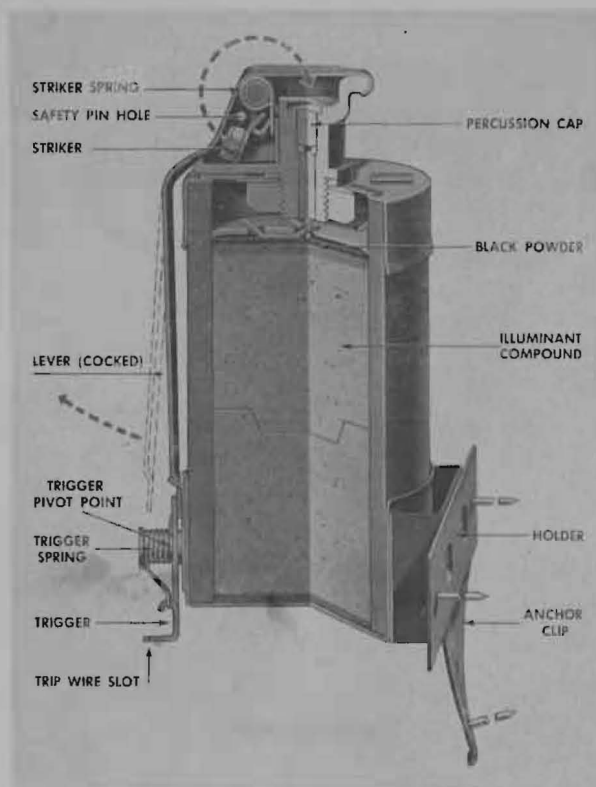
**USE**

Warning device in mine fields and other obstacle areas. Burns brilliantly for one minute. Fired by 2 to 9 pound pull on a trip wire.

DESCRIPTION

Pull on trigger releases lever; allowing striker to detonate percussion cap, and lighting black powder which removes cap and ignites illuminant compound. Constructed of metal as shown, with mounting straps to attach flare to wooden stake or other support. Unit package contains 16 hand grenade type fuzes, 1 holder, 3 nails, 1 spool containing 45 feet of trip wire.

CONNECTING ITEMS

None required for operation.

REFERENCES

FM 5-31 p. 54.02

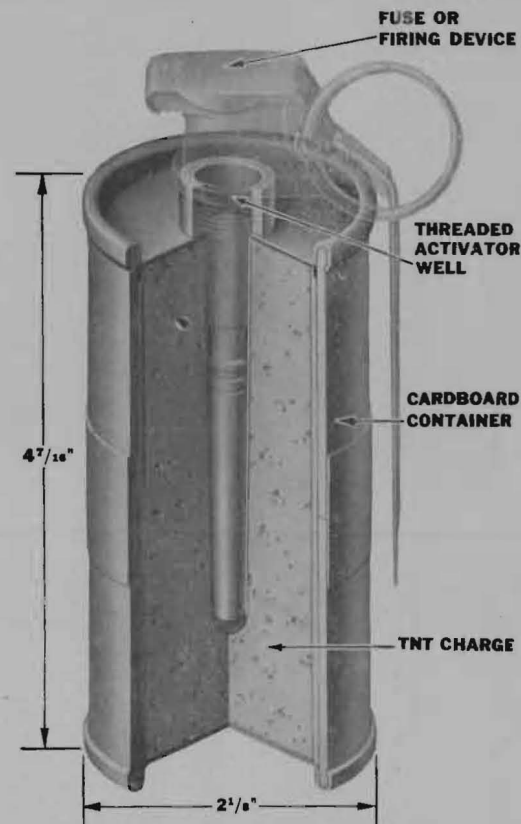
**USE**

Concussion-type antipersonnel charge used as grenade, in booby traps or to detonate larger charges. Usually detonated by Hand Grenade Fuze M6A4 or any firing device that will hold non-electric cap inserted in threaded activator well. Stocks available but additional production not in progress (p. 10).

DESCRIPTION

½ lb. pressed TNT charge in round cardboard container with metal ends. Fitted with standard threaded cap well as shown.

CONNECTING ITEMS

Detonated by Fuze, Detonating, Hand Grenade, M6A4 (16.10). Detonated by Cap, Blasting, Special, Nonelectric (11.01) crimped onto the standard coupling base of any firing device.

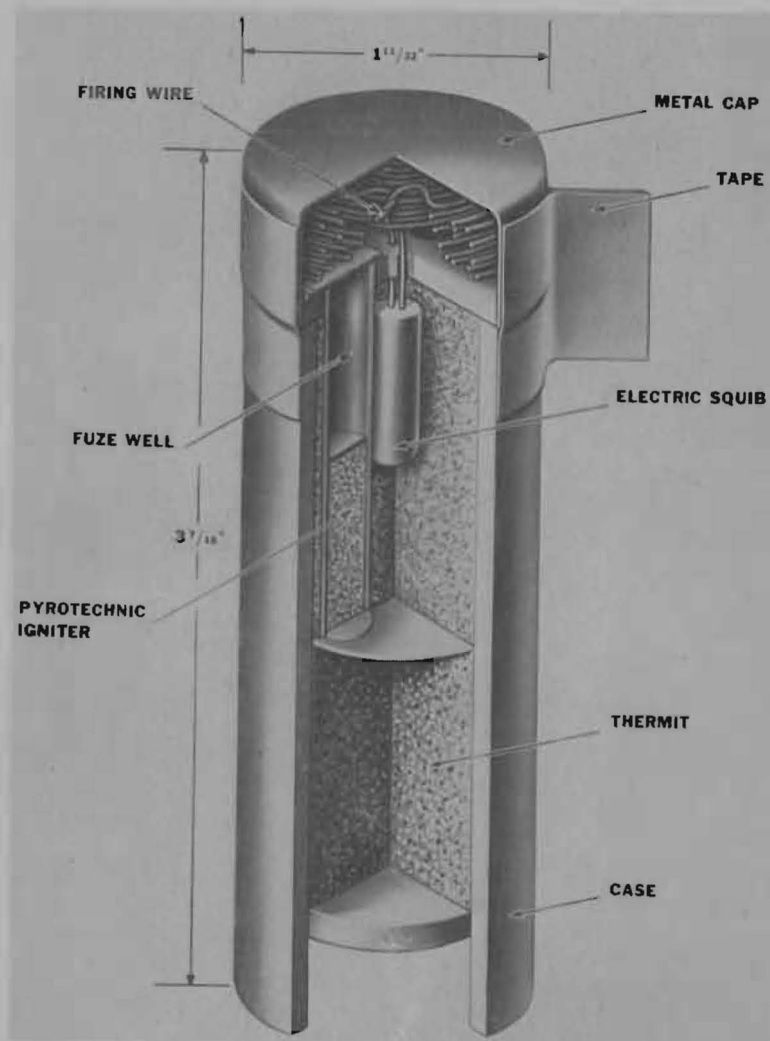

USE

Ignites bulk thermit or other combustible material.

DESCRIPTION

Waterproof plastic case containing explosive and pyrotechnic mixtures. Fired by safety fuse fitted into fuse well, or electric impulse to igniting cap.

CONNECTING ITEMS

Detonated by Fuse, Blasting, Time (12.01) or by electric impulse from Machines, Blasting (13.01 or 13.03), or by Timer and Battery Box Mark 3 Mod. 0 (15.10).

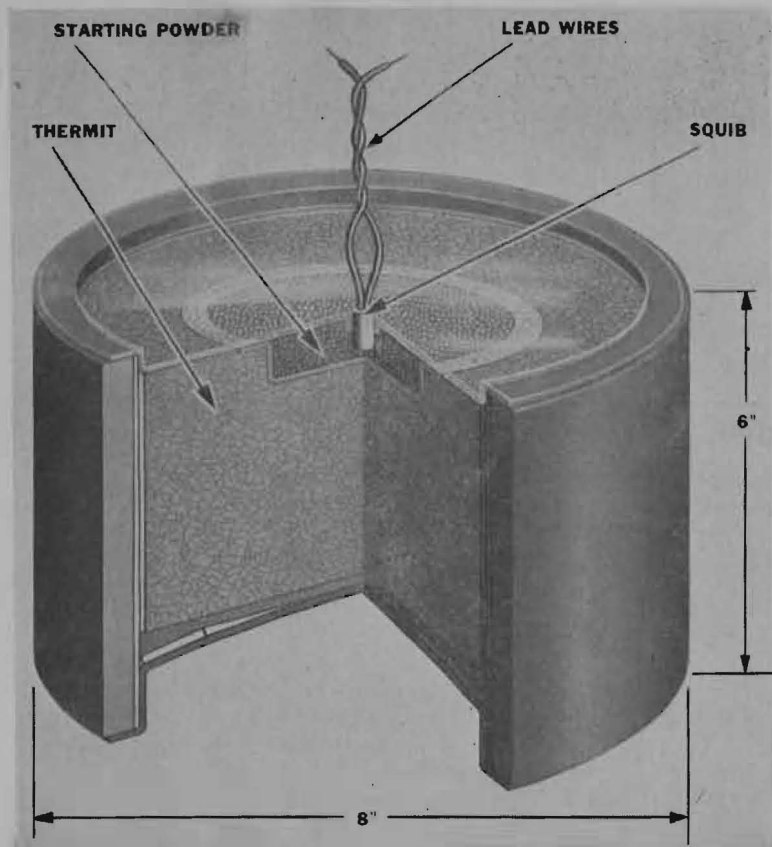

USE

Ignites combustible material and melts metal equipment with intense heat and flame. Initiated by electric impulse.

DESCRIPTION

Electric impulse fires squib, which ignites starting powder, starting combustion of 16½ lb. thermit charge. Enclosed in asbestos-cement cylinder with plastic ends as shown.

CONNECTING ITEMS

Detonated by Machines, Blasting (13.01), or (13.03), Timer and Battery Box Mark 3 Mod. 0 (15.10), or other electric source.

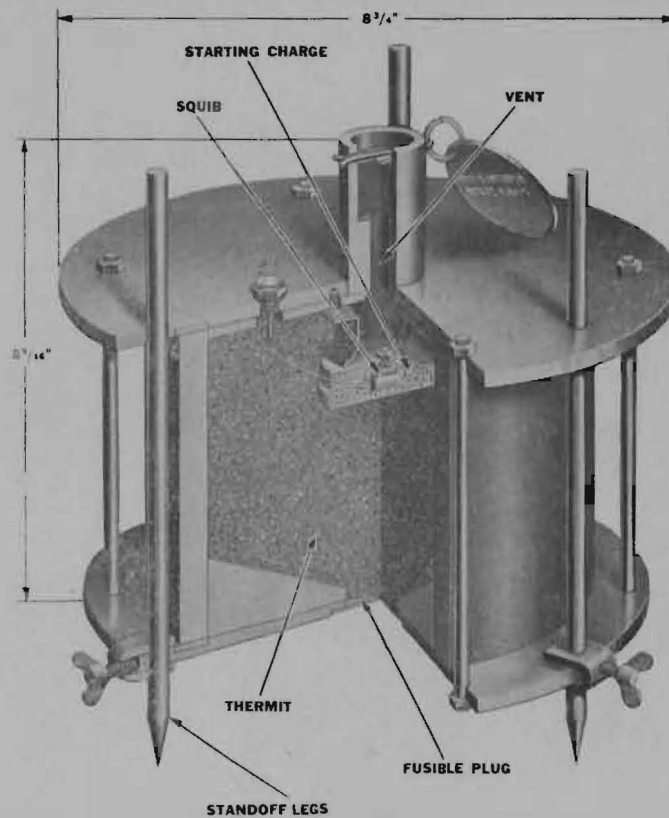

USE

Primarily for mine disposal use (p. 10). Burns through steel plates and other metallic objects under water. Fired by electric impulse.

DESCRIPTION

Electric impulse fires squib, igniting starting charge and 8½ pound thermit charge. Constructed as shown in asbestos cement cylindrical housing with brass ends, adjustable standoff legs, and gasketed vent.

CONNECTING ITEMS

Detonated by Machines, Blasting (13.01 or 13.03), Timer and Battery Box, Mark 3 Mod. 0 (15.10), or other electric source.

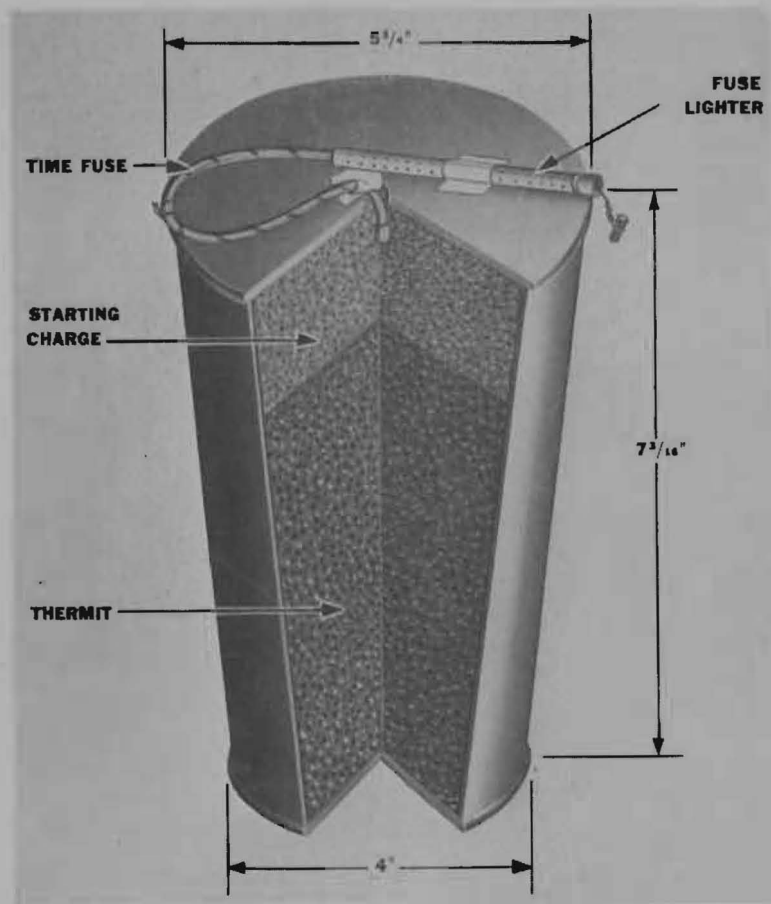

USE

Ignites combustible material and destroys metal equipment with intense heat and flame. Fired by time fuse.

DESCRIPTION

Flash of flame from time fuse inserted in opening at top ignites starting charge and 10 pound thermit charge. Furnished complete in light alloy metal can as shown, with 30 second length of time fuse and pull wire fuse lighter.

CONNECTING ITEMS

None required for operation. For longer time delays insert required length of **Fuse, Blasting, Time (12.01)** into opening at top of unit. For positive ignition, especially under adverse conditions use **Lighter, Fuse, Weatherproof, M2 (14.31)**.

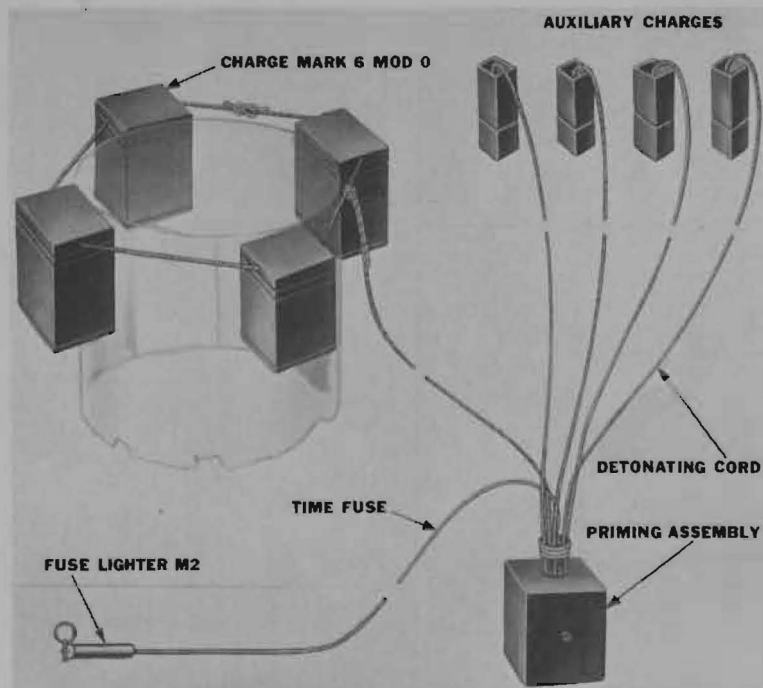

USE

Complete equipment for destruction of certain secret and confidential apparatus.

DESCRIPTION

Consists of four Demolition Charges Mark 6 Mod. 0 and four half-pound TNT auxiliary charges connected by twenty-foot lengths of detonating cord through a junction block, containing a No. 8 commercial Nonelectric Blasting Cap crimped on a thirty-minute length of Time Blasting Fuse leading to Fuse Lighter M2 (14.31). Earlier issue (Mod. 0) contains Friction Type Fuse Lighter M1 (14.30). Outfit packed in wooden chest. See following columns for descriptions of components.

CONNECTING ITEMS

None required for use. Additional charges may be tied into firing lines with Cord, Detonating (17.01, 17.02, 17.03).

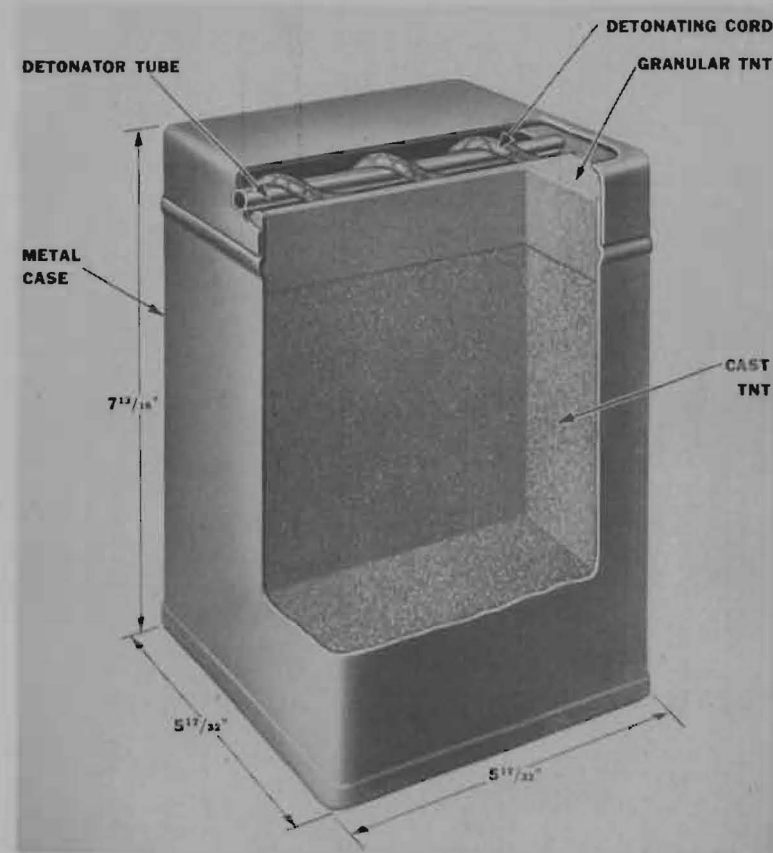

DEMOLITION CHARGE MARK 6 MOD. 0

Demolition Charge Mark 6 Mod. 0 is 10½ pounds of cast TNT, with a 1½ pound granular TNT booster, contained in a steel can fitted with a metal tube through which Detonating Cord is threaded for firing. Available only as one component part of this outfit.

REFERENCES

OP 995, OCL A51-43

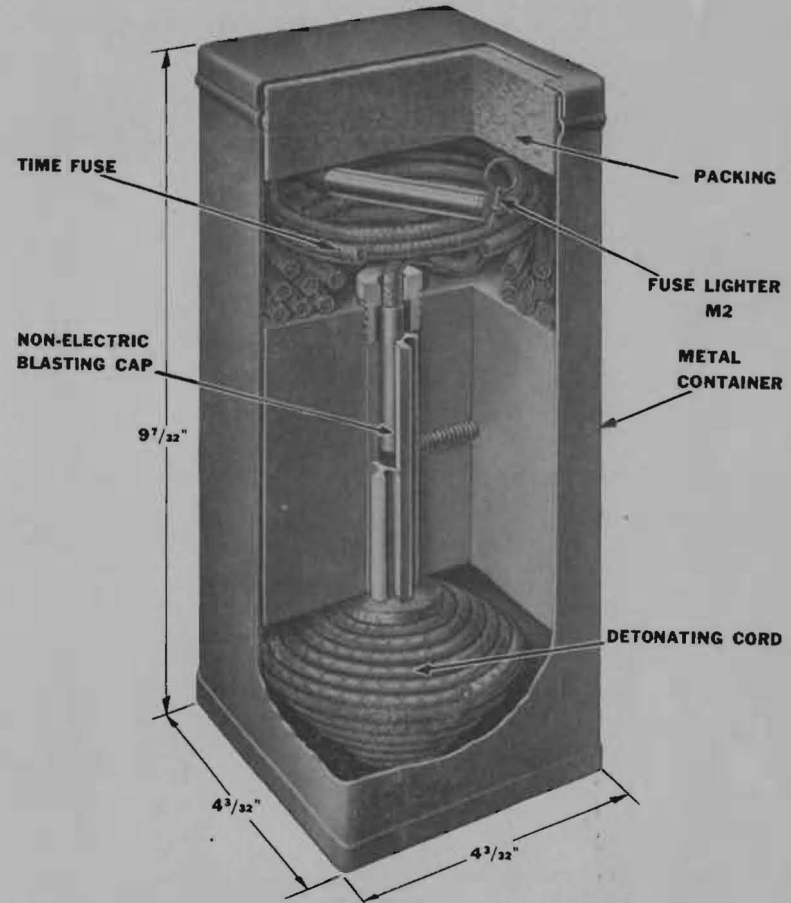
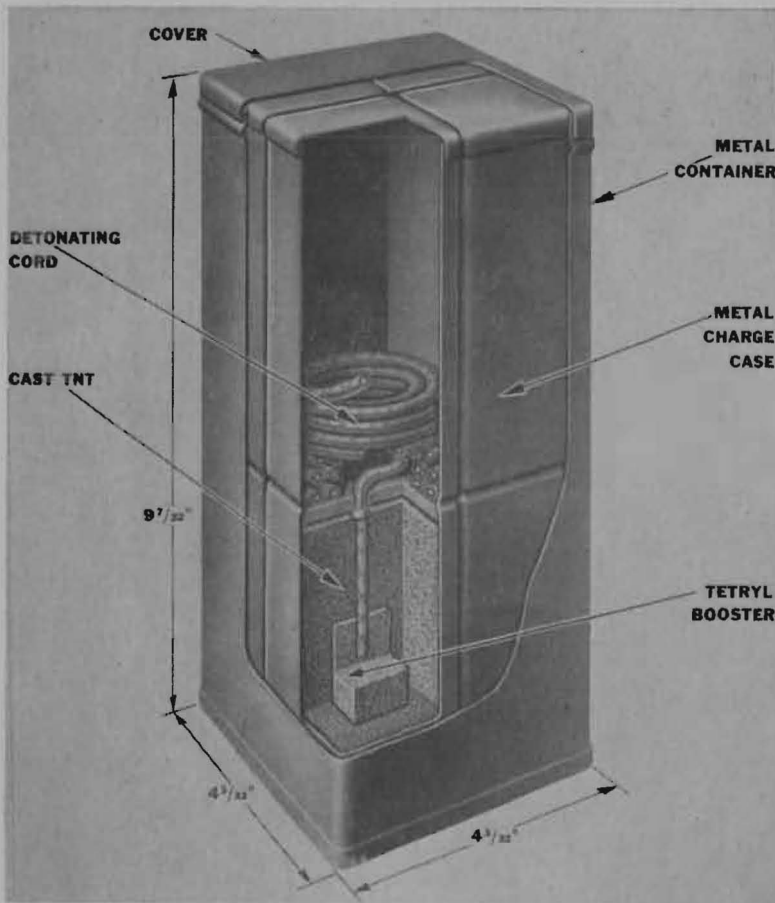

PRIMING ASSEMBLY

The Priming Assembly includes a cast iron junction block containing a No. 8 Commercial Nonelectric Blasting Cap crimped to a thirty foot length of Time Blasting Fuse, for which a Fuse Lighter M2 (14.31) is provided. Surrounding the blasting cap are six wells into which the Detonating Cord leads from the charges are inserted. The Priming Assembly is supplied in a metal can which also contains thirty feet of Detonating Cord for connection to the Charges Mark 6, Mod. 0. Available only as one component part of this outfit.

AUXILIARY CHARGES

Four Auxiliary Charges are packed in one sealed metal can as shown. Each charge is a half-pound pressed TNT block with twenty feet of Detonating Cord, packed in an individual metal can. Available only as component parts of this outfit.

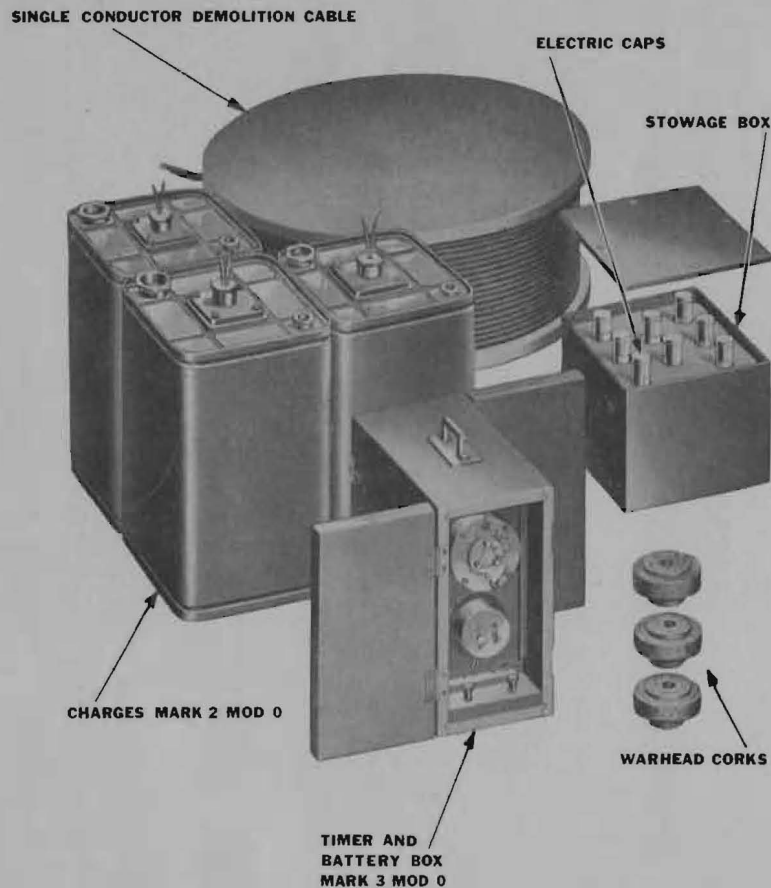

USE

Assembly of charges and equipment for scuttling and destruction of submarines (p. 10).

DESCRIPTION

This outfit consists of the following components which are described in detail under the individual item headings:

- 3 Charge, Demolition, Mark 2 Mod. 0 (31.19)
- 1 Timer and Battery Box Mark 3 Mod. 0 (15.10)
- 8 Cap, Blasting, Special Electric (11.02) Stowed in
- 1 Box, Electric Cap (43.10)
- 600 feet Cable, Demolition, One Conductor (41.01)

CONNECTING ITEMS

None required for operation other than 8 No. 6 Dry Cells already listed as required for the Timer and Battery Box Mk. 3 Mod. 0 (15.10).

REFERENCES

OP 1012; OCL A78-43

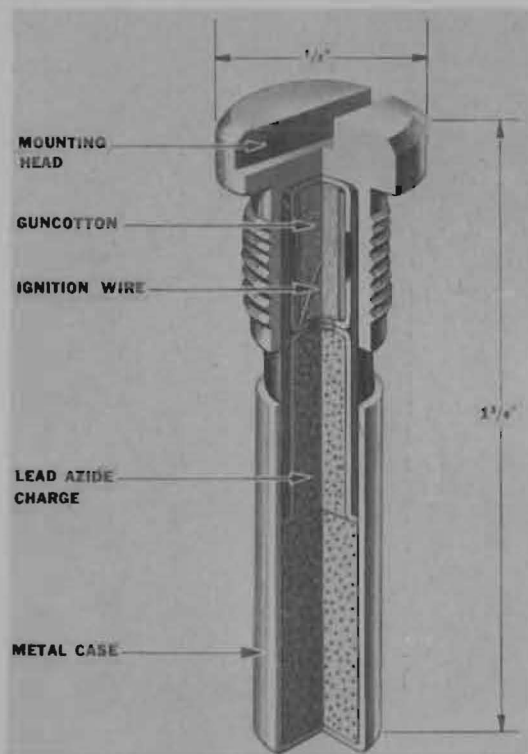
**USE**

Destruction of confidential and secret equipment. Issue is limited to correspond with location of certain confidential and secret equipment which has the necessary special mountings.

DESCRIPTION

Electric current between detonator case and mounting head heats ignition wire, which fires guncotton, detonating 1.7 gram lead azide charge. Contained as shown in metal case with threaded head. Case also acts as electric connector for detonator.

CONNECTING ITEMS

Mating electric mounting and firing mechanism are provided in apparatus to be destroyed.

REFERENCES

OP 995; OCL AV4-44; OCL A4-42; TB Ord 51

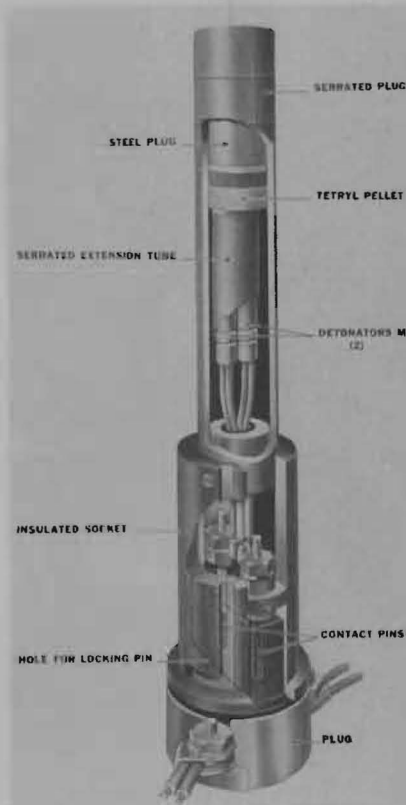
**USE**

Destruction of secret and confidential equipment. Issue is limited to correspond with location of certain confidential and secret equipment which has the necessary special mountings.

DESCRIPTION

Consists of a serrated metal tube containing two electric detonators and a two-gram tetryl pellet, with an electric receptacle at outer end.

CONNECTING ITEMS

Mating electric plug, cable, and firing switch are provided in apparatus to be destroyed.

REFERENCES

OP 995; OCL AV4-44; OCL A4-42; OCL A51-43; OTI A3-43; TB Ord 51

The equipment described in this Chapter is that equipment not listed in Chapters 1, 2, or 3 which is designed to aid in the proper use, handling, and stowage of demolition charges. The Chapter is divided into the following sections according to use:

Section 1—FIRING WIRE

Electrical cable, cable reels, and other equipment which is used to carry electric firing current to demolition charges are included in this section.

Section 2—SPECIAL EQUIPMENT

Tools, testers, and miscellaneous handling equipment useful in the preparation of charges are included in this classification.

Section 3—CONTAINERS

Chests, boxes and carrying packs designed especially for the proper stowage of explosive charges in the field are included in this section.

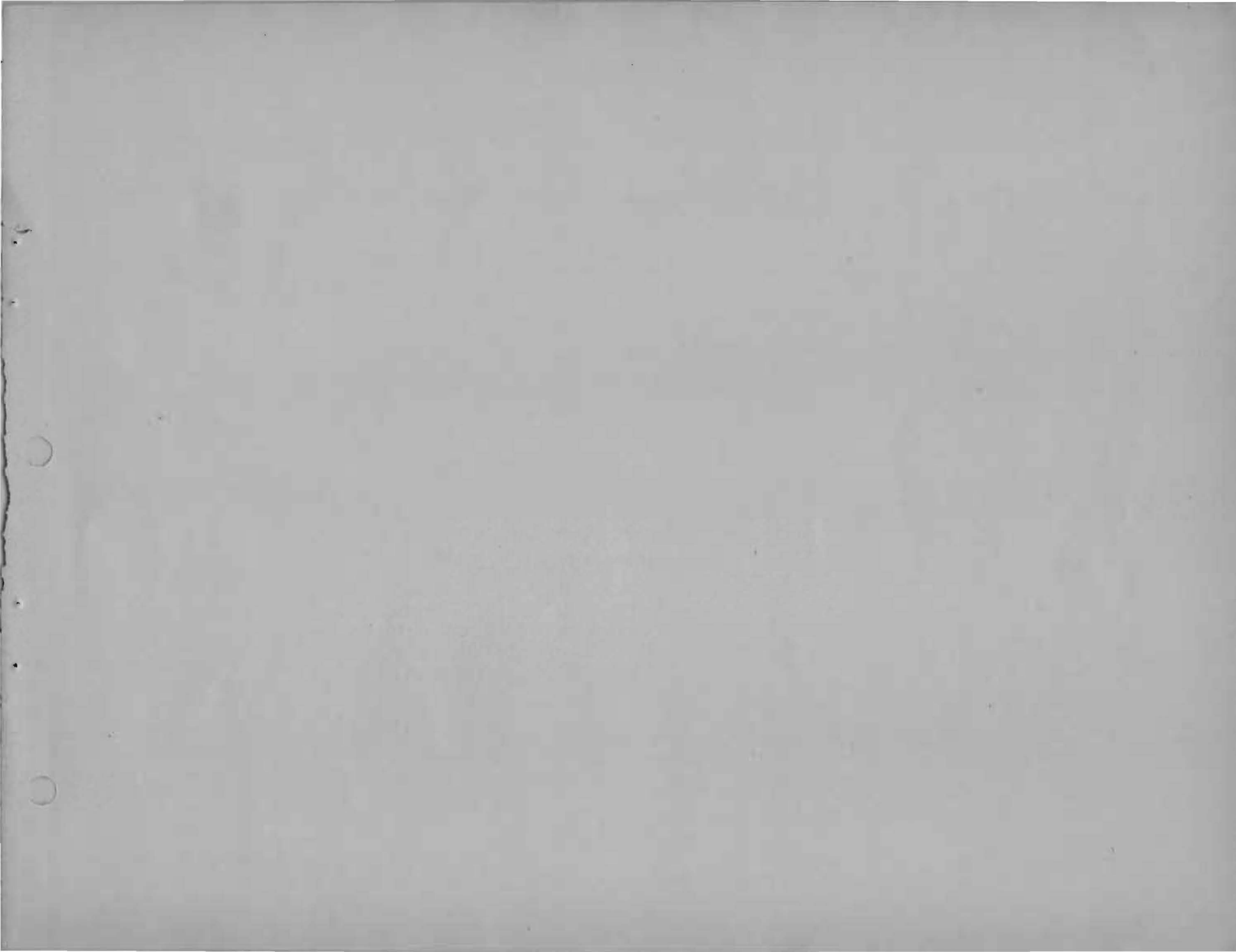

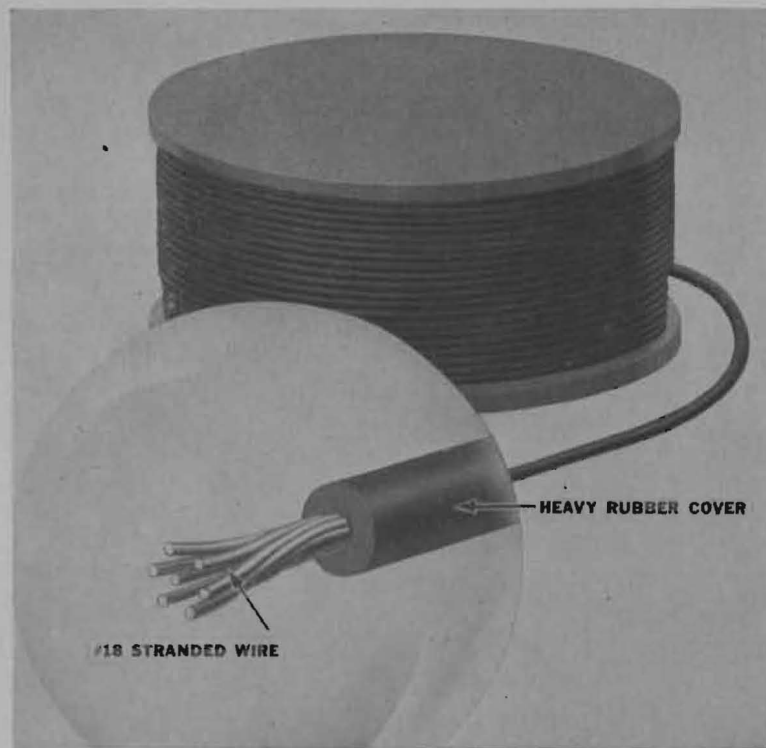
**USE**

Connects lead wires of electric blasting caps to make up firing circuits. Particularly useful in series circuits. Abrasion-resistant thick outer covering.

DESCRIPTION

Seven-strand No. 18 tinned copper wire with extra heavy natural rubber covering. Furnished in 1000 ft. coils.

AUXILIARY COMPONENTS

Connects Cap, Blasting, Special Electric (11.02) to Machines, Blasting (13.01 or 13.03), or other source of electric power.

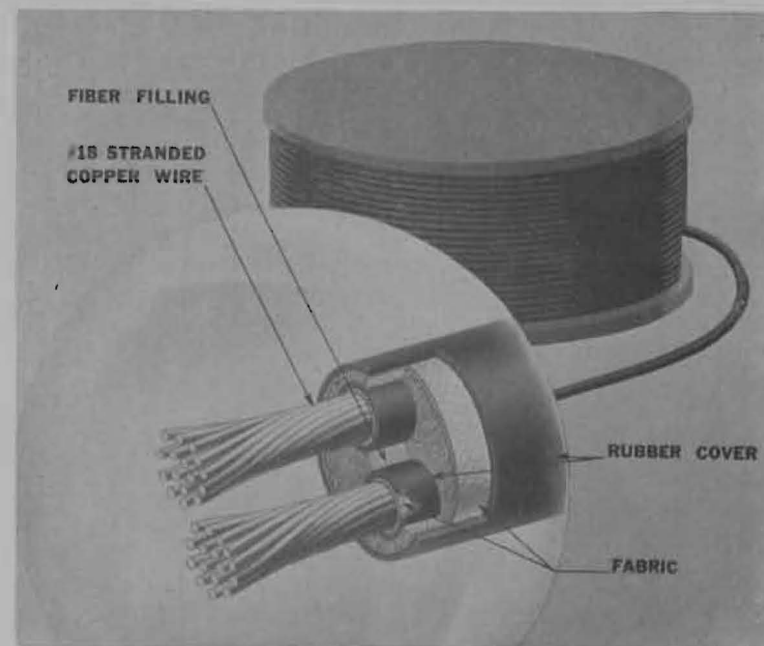
**USE**

Connects electrically fired items or groups of them to blasting machines or other electric current source.

DESCRIPTION

Round rubber or synthetic rubber-covered cable containing two Number 18 stranded copper conductor, individually covered with rubber and wrapped with cotton fabric, separated by a jute or cotton filler. Furnished in five hundred foot coils weighing sixteen pounds per five hundred feet. The resistance is 6.38 ohms per 1000 feet of each conductor. Tensile strength is 160 pounds.

CONNECTING ITEMS

Connects Cap, Blasting, Special Electric (11.02) to Machine, Blasting (13.01 or 13.03) or other source of electric power.

REFERENCES

RM 5-25 p. 20

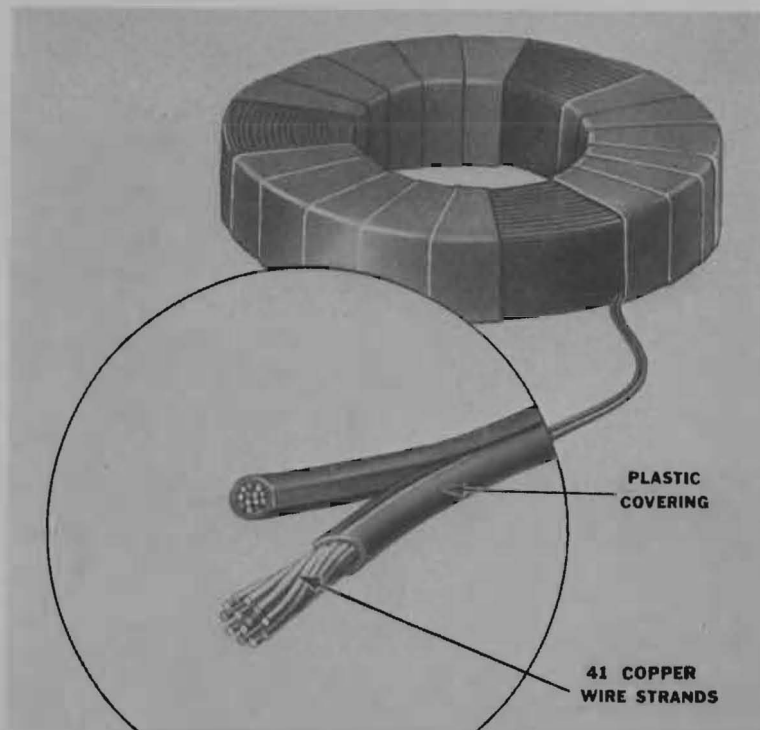

USE

Connects electrically fired items or groups of them to blasting machines or other electric current supply. Only limited stocks available. No further Navy Procurement.

DESCRIPTION

Two No. 18 tinned copper .41 stranded conductors laid parallel and encased in polyvinyl covering. Covering creased for easy separation of conductors. Furnished in 500 foot paper-wrapped coils weighing 10 pounds per 500 feet. The resistance is 6.38 ohms per 1,000 feet of each conductor. Tensile strength is 100 pounds.

CONNECTING ITEMS

Connects Cap. Blasting, Special Electric (11.02) to Machine, Blasting (13.03) or other source of electric power.

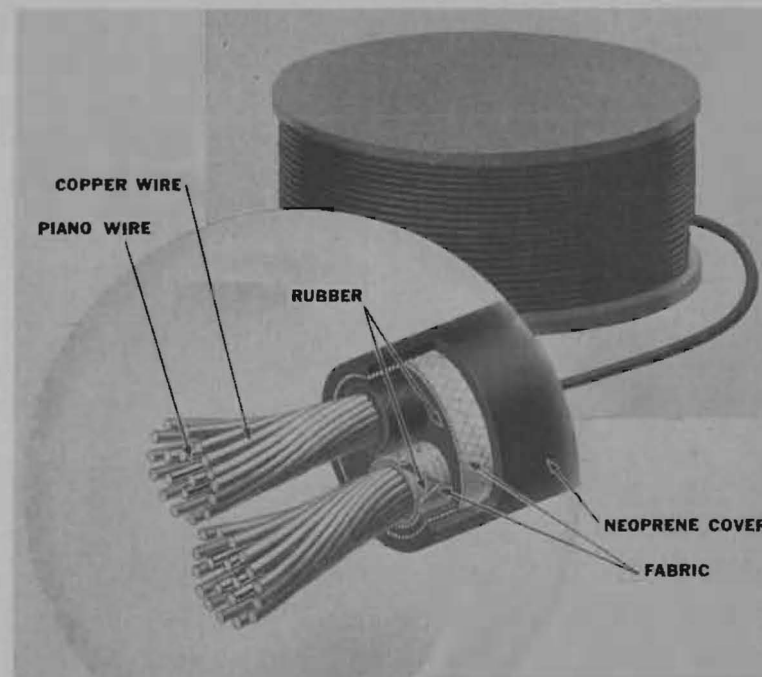

USE

Connects electrically fired items or groups of them to blasting machines or other electric current sources.

DESCRIPTION

Each conductor made up of five strands of copper wire. The two conductors are wrapped in rubber with cotton fabric covering, as shown, and the whole assembly covered with a tough neoprene outer covering. Furnished in 1000 foot coil. Heavy duty oil resistant cable with tensile strength of 1000 lbs. Resistance of each conductor is 5 ohms or less per 1000 feet.

CONNECTING ITEMS

Connects firing systems containing Cap. Blasting, Special Electric (11.02) to Machine, Blasting (13.01 or 13.03), or other source of electric power.

REFERENCES

OS 718

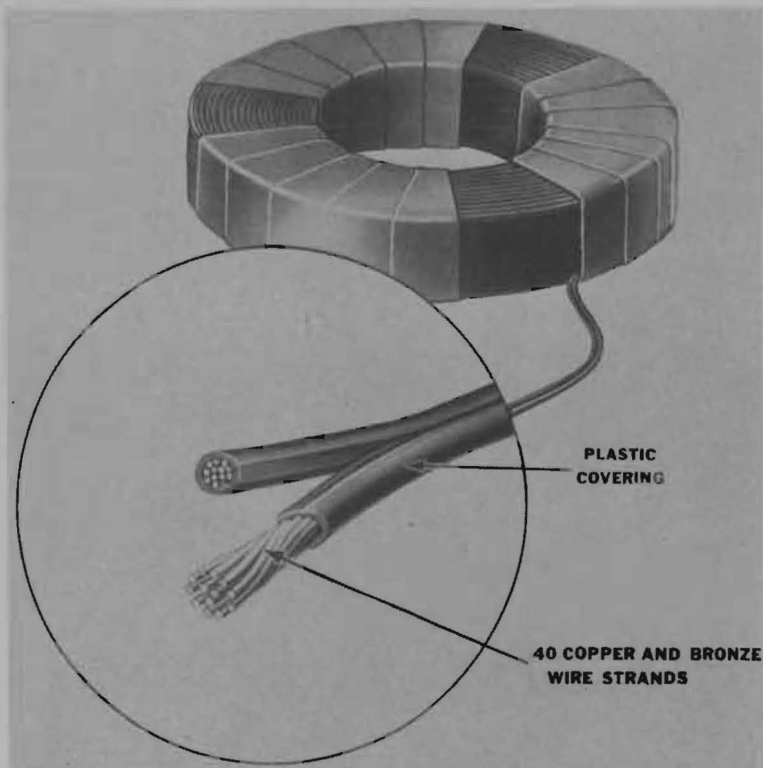

USE

Connects electrically fired items or groups of them to blasting machines or other electric current supply.

DESCRIPTION

Same general appearance as Army Lightweight Firing Wire (41.03). Two No. 18 tinned, 40 stranded combination of copper and bronze, conductors laid parallel and encased in polyvinyl covering. Covering creased for easy separation of conductors. Furnished in 1000 foot paper-wrapped coils. Weight is 20 pounds per 1000 feet. Resistance of each conductor is 10 ohms or less for 1000 feet.

CONNECTING ITEMS

Connects Cap, Blasting, Special Electric (11.02) to Machine, Blasting (13.01 or 13.03) or other source of electric power.

REFERENCES

OS 1448

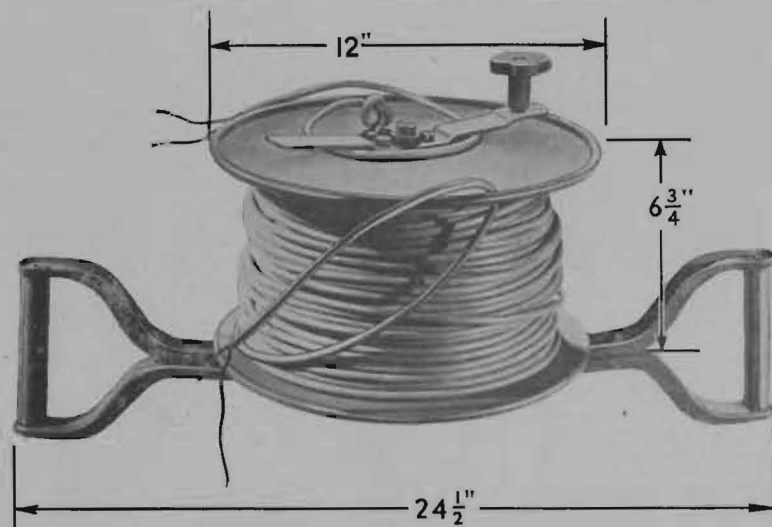
**USE**

Carries firing wire for electrically connecting fired items or groups of them to blasting machines or other sources of firing current.

DESCRIPTION

Metal reel, with detachable handles capable of carrying 500 feet of Wire, Firing, Double Conductor Army (41.02) or 1000 feet of Wire, Firing, Double Conductor Navy Lightweight (41.05). Inner end of wire to be attached to current source and other end connected to electric blasting cap wires in charge. Extra lengths to be attached if needed for safe distance. Reels furnished without wire.

CONNECTING ITEMS

Machines, Blasting (13.01 or 13.03) or other power source.
Cap, Blasting, Special Electric (11.02).

REFERENCES

FM 5-25 p. 20

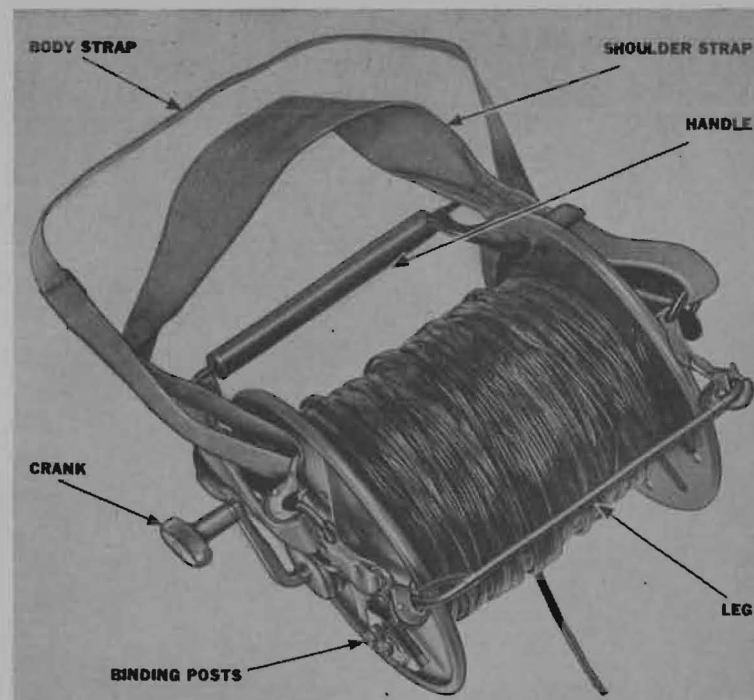
**USE**

Carries firing wire for electrically connecting fired items or groups of them to blasting machines or other sources of firing current.

DESCRIPTION

Metal reel, with carrying handles (can also be used as stand), capable of carrying 500 feet of Wire, Firing, Double Conductor, Army (41.02) or 1,000 feet Wire, Firing, Double Conductor Navy Lightweight (41.05). Inner end of wire made to be attached to current source and other end connected to electric blasting cap wires in charge. Extra lengths to be attached if needed for safe distance. Reels furnished without wire.

CONNECTING ITEMS

Machines, Blasting (13.01 or 13.03) or other power source.
Cap, Blasting, Special Electric (11.02).

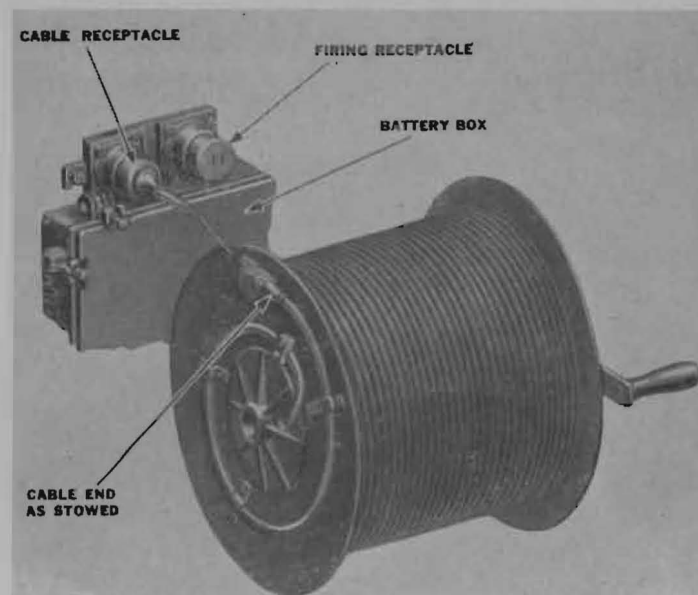
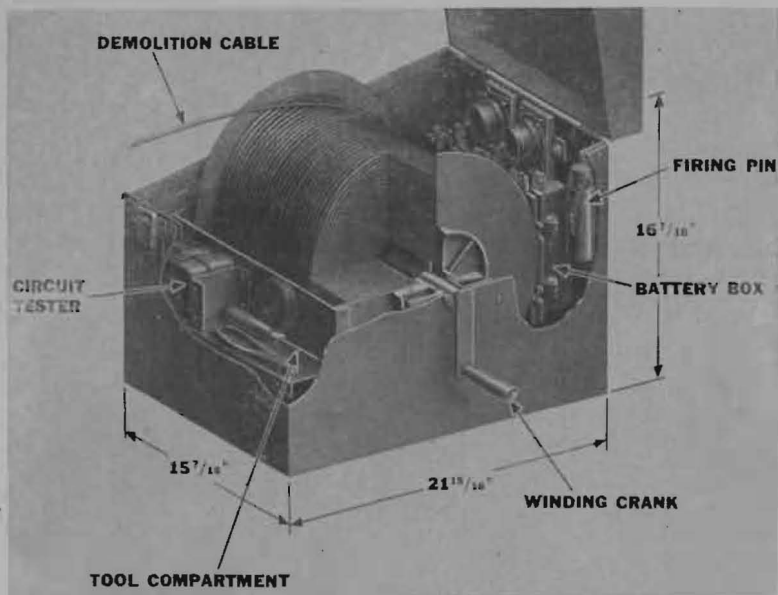

USE

Provides power source, firing key, circuit tester and firing wire enclosed in single container. Normally issued only by allowance list to certain classes of ships and units (p. 10).

DESCRIPTION

Steel carrying chest containing 1000 feet of Cable Demolition (41.04) wound on a free-running steel spool with detachable winding crank, water-tight battery case which will hold 3 dry batteries, firing key, ohmmeter circuit tester, friction tape, pliers, and screwdriver as shown. Required for operation but not furnished; 3 batteries (Navy Specification 17B7, type C) (Supply Depot Item).

CONNECTING ITEMS

3 type C flashlight batteries are connected and held inside the battery case. Connects at unreeled end of cable to Cap, Blasting, Special Electric (11.02).

By barring the conductors, leading from the inside of the reel, Galvanometer, Blasting (42.01) may be used for testing the firing circuit through the cable to the blasting cap, and Machine, Blasting, Ten Cap (13.01) may be used for firing.

REFERENCES

OP 741

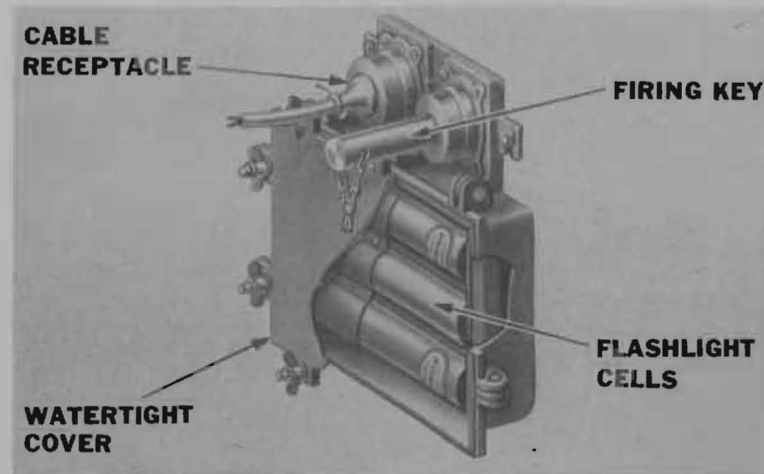

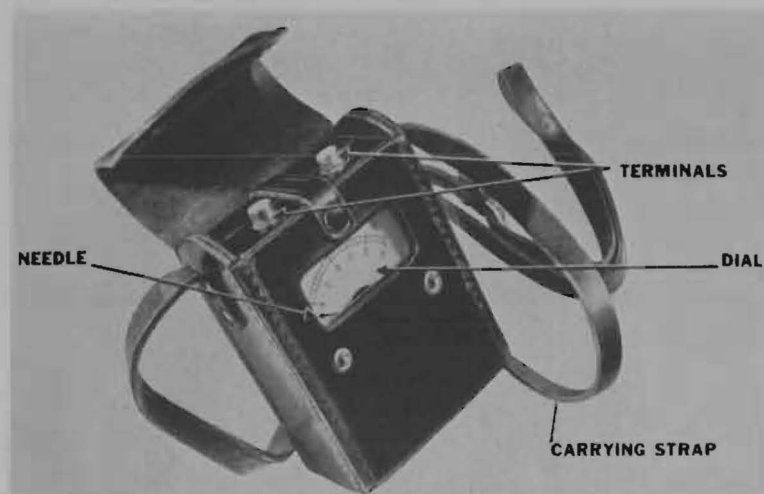

USE

Tests electric blasting caps and firing circuits.

DESCRIPTION

Plastic case containing a small silver chloride cell, a sensitive indicating meter, and terminals for momentary connection to circuit to be tested. Deflection of needle across dial indicates closed circuit. Current output is so small that it has been used for a number of years in peacetime to test blasting caps without detonating them. A more accurate name applied to these instruments would be circuit testers, but they have long been known as blasting galvanometers. Leather case and carrying strap is furnished with the circuit tester.

REFERENCES

FM 5-25 p. 18; OD 2104; BH p. 57

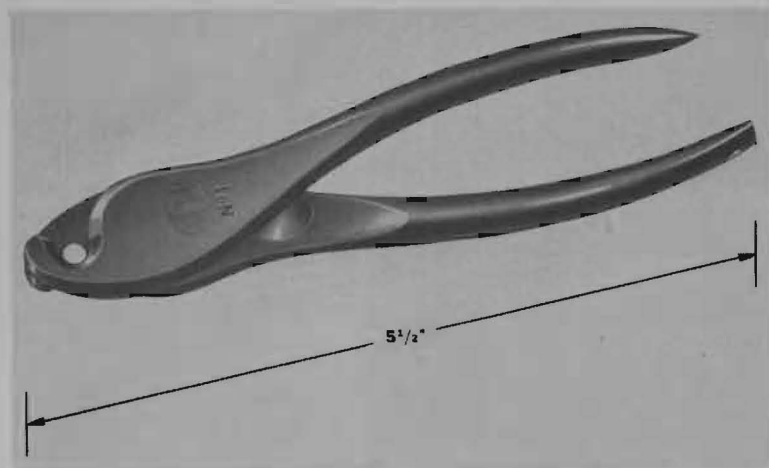
**USE**

Crimps Nonelectric Blasting Caps around Time Fuse or around Coupling Base of firing devices. Provides watertight seal and secures cap in position.

DESCRIPTION

Forged steel pincers with jaw opening which provides continuous crimp around cap case when closed. One leg of handle pointed for use as punch.

REFERENCES

BH p. 51

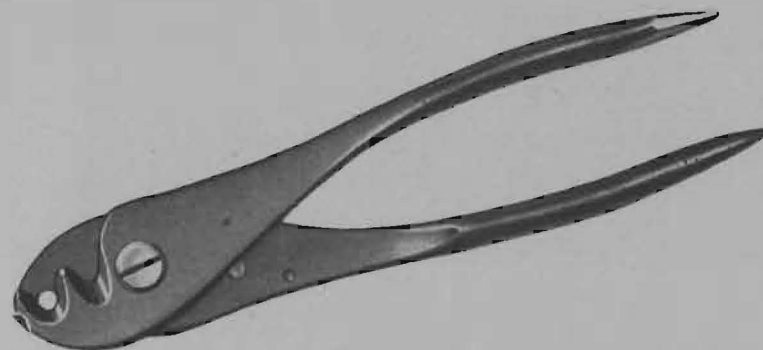
**USE**

Crimps nonelectric blasting caps around time fuse and provides waterproof seal. Cuts time fuse in proper manner. May also be used as screwdriver and punch. Listed for identification purposes. None available at present in Bureau of Ordnance Stock.

DESCRIPTION

Steel pincers with outer jaw opening for squeezing cap case. Inner opening shaped and sharpened for cutting fuse. One leg of handle pointed for punching holes, other leg with screwdriver end. Not to be used as pliers or wire-cutters.

REFERENCES

FM 5-25 p. 25; BH p. 51

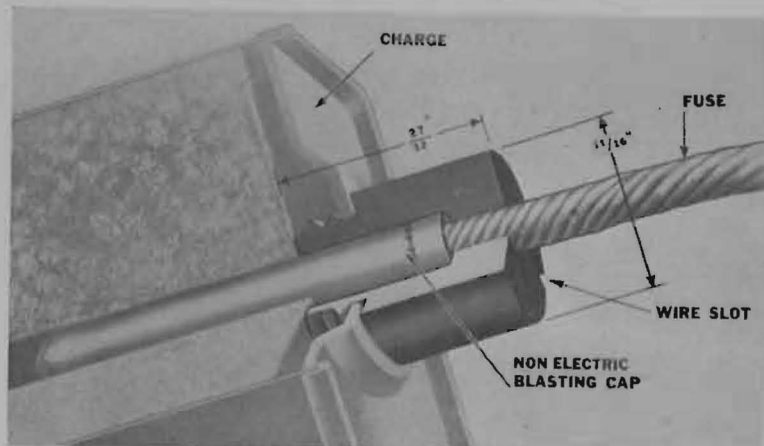
**USE**

Provides waterproof seal between nonelectric cap and time fuse or between nonelectric cap and coupling base. Seals detonating cord ends. Effective against moisture above water but not reliably waterproof under water.

DESCRIPTION

Black viscous material which hardens on exposure to air. Issued in half-pint containers.

CONNECTING ITEMS

Applied to outside of Fuse, Blasting, Time (12.01), Cord Detonating (17.01, 17.02, 17.03), or tips of coupling bases, on firing devices.

REFERENCES

FM 5-25 p. 30; BH p. 59

USE

Secures electric or nonelectric blasting caps in standard threaded activator well.

DESCRIPTION

Olive drab plastic cylinder. Collar at one end restricts inside diameter to size accommodating Detonating Cord (17.01, 17.02), or Fuse Blasting, Time (12.01) but too small for removal of blasting cap. Slotted longitudinally for easy insertion of wires to electric blasting cap. Other end has threads to screw into standard activator well. See Appendix III on standardization of dimensions.

CONNECTING ITEMS

Used with blasting caps in charges having standard threaded activator wells.

REFERENCES

FM 5-25 p. 26; TB Eng 8, p. 17

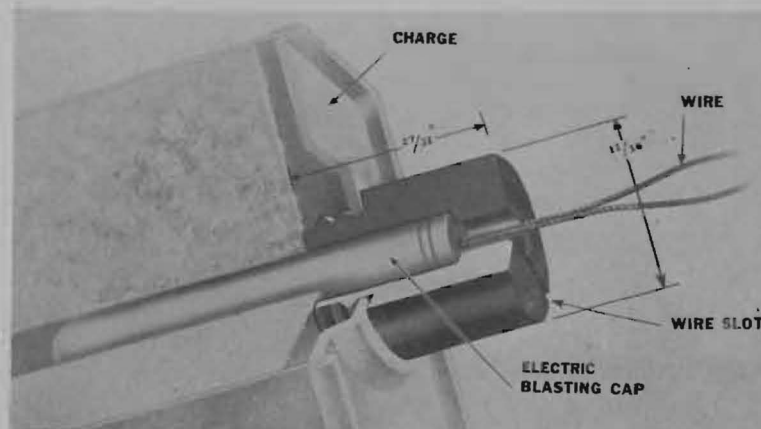

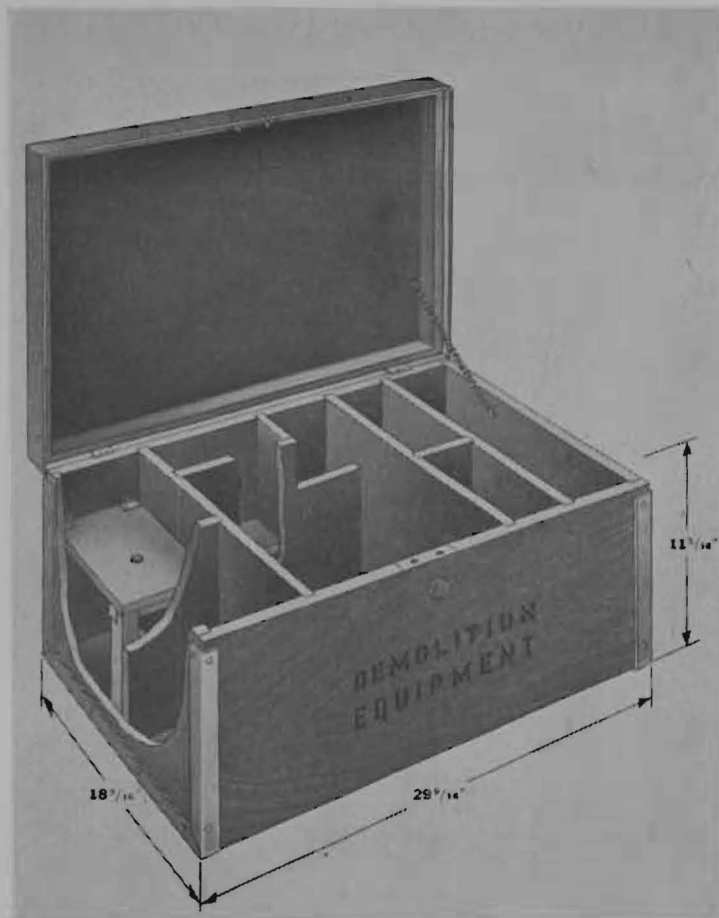
**USE**

Compartmented chest for general field use for demolition materials stowage.

DESCRIPTION

Metal bound hardwood chest with tumbler lock and metal carrying handle on each end. Constructed as shown with removable partitions and closed compartments.

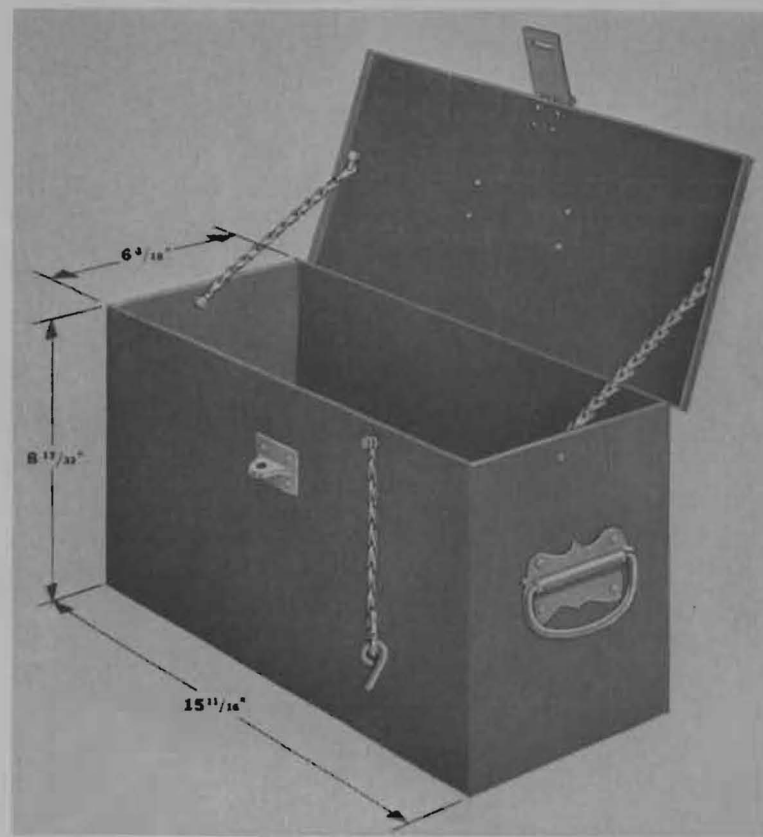
**USE**

Container for stowage of charges or miscellaneous demolition equipment. Normally issued only by allowance list to certain classes of ships and units.

DESCRIPTION

Sheet steel case with hinged cover, hasp and locking pin constructed as shown. Steel handles at each end.

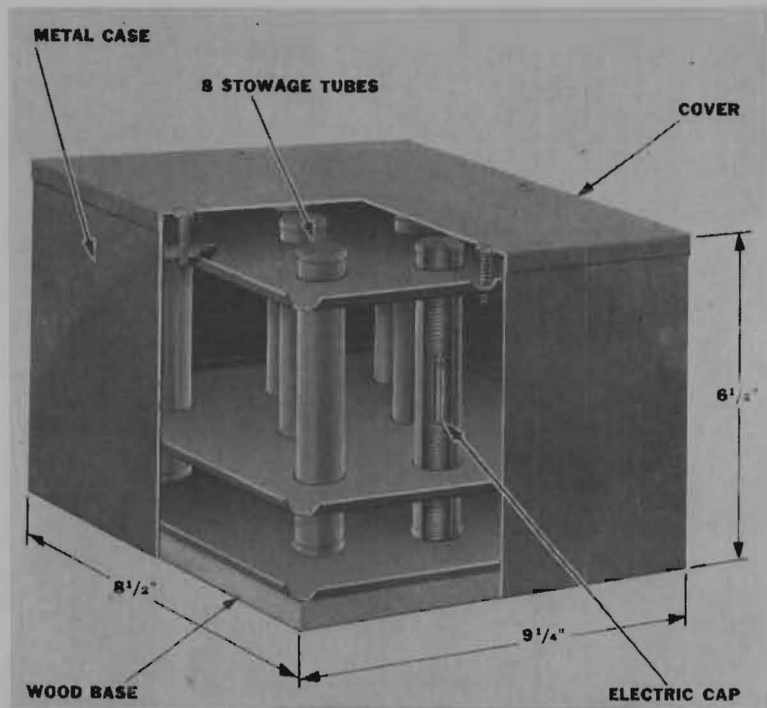
Box, Electric Cap**43.10****USE**

Holds eight Special Electric Blasting Caps as required for continuous shipboard stowage.

DESCRIPTION

Sheet metal case with screw-on cover containing eight isolated metal tubes in which Special Electric Blasting Caps are packed as shown. Box designed so that detonation of one special Electric Blasting Cap will not detonate the others.

CONNECTING ITEMS

Contains Cap, Blasting, Special Electric (11.02).

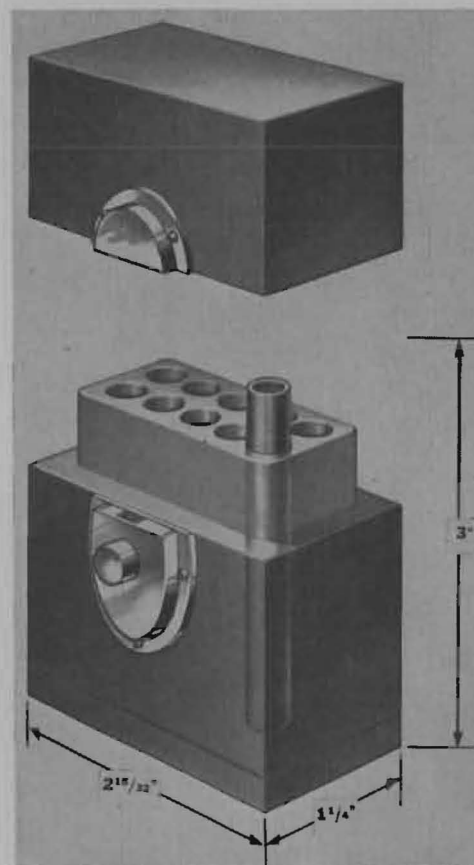
82**Box, Nonelectric Cap****43.11****USE**

Holds ten Special Nonelectric Blasting Caps properly protected for field use.

DESCRIPTION

Wooden block cut and drilled as shown. Removable cover with snap lock.

CONNECTING ITEMS

Contains Cap, Blasting, Special Nonelectric (11.01).

RESTRICTED

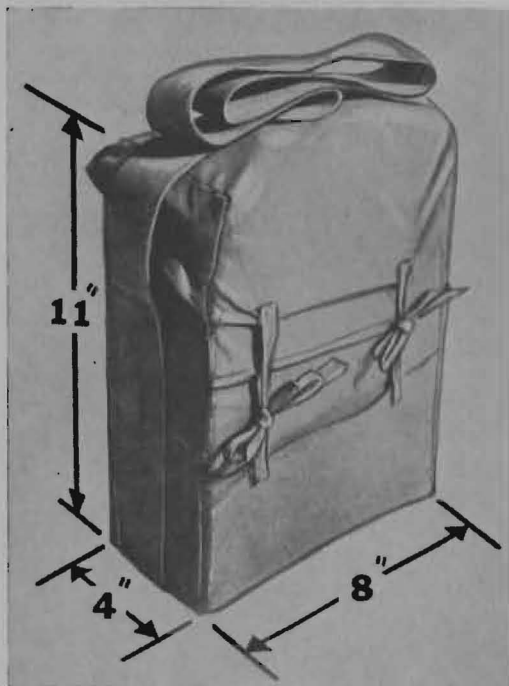
**USE**

Handy carrying pack for demolition blocks, prepared charges, or miscellaneous supplies.

DESCRIPTION

Heavy olive drab canvas pack constructed as shown with shoulder strap and cover flap secured by canvas tie straps.

CONNECTING ITEMS

Furnished as standard container for Blocks, Demolition, Chain, M1 (31.03), Block, Demolition M2 (31.04), Blocks, Demolition, M3 (31.05).

REFERENCES

FM 5-25



Demolition material is listed here in the order that it appears in the catalog, tabulated to show all the information which would normally be necessary in procuring, identifying, handling, and stowing this material. (In order to show the necessary information this index has been divided into columns as follows):

INDEX NUMBER

In this column are found in numerical order the same decimal index numbers found in bold type on the pages devoted to description of the items of equipment.

OFFICIAL DESIGNATION

In this column are found the proper official nomenclatures to be used in ordering.

SPECIFICATIONS AND DRAWINGS

In this column is given information positively linking the official nomenclature to the item of demolition equipment. This would be useful to activities receiving material direct from contractors. There is a listing of applicable Navy or Army general arrangement drawings. Where no drawings exist Navy or Army Specifications have been listed. For commercial items a Federal Specification is listed where it exists. For other commercial items identified by name the company applying such name is stated.

ARMY CODE NUMBERS

Either the stock number shown in the Army Engineer Supply Catalog (ENG-5) or the code symbol shown in the Army Ordnance Supply Catalog (ORD-11) is shown for items procured from the Army by the Bureau of Ordnance.

NAVY CODE NUMBER

Every item listed (except some Demolition Outfits) has a Navy stock number. This identifies the item on the records of all Supply Activities.

ORDERING UNIT

In this column, the unit of ordering (such as each, feet, reels, pounds, blocks, chains, haversacks, boxes) is specified so that in planning, procurement, ordering, and shipping, the exact quantity involved will be understood by all parties concerned.

METHOD OF PACKING

The quantity of items available in the smallest unit container, the number of containers in a standard carton, and the number of cartons supplied in a standard overseas shipping box are listed here with an indication of the Type of container used. The total quantity of the item packed in the largest container is shown in parenthesis.

DIMENSIONS

The overall outside length, width, and height of the largest container are shown in feet. The horizontal length and width and the vertical height dimensions correspond to the normal position of the package in stowage.

AREA

The square feet area shown is the product of the length and width of the largest container in the position normally stowed.

VOLUME

The overall outside volume of the largest container is listed in cubic feet, and is the product of the length, width, and height shown.

WEIGHT

The weight in pounds shown here is the actual gross shipping weight of the largest container and its contents.

UNIT PACKAGE INDEX

Index Number	Official Designation	Specification or Dw'g. No.	Army Code Number	Navy Code Number
11.01	Cap, Blasting, Special Nonelectric *	AES T1267, AS 49-20	04-2584, 500-500	211-1000-E
11.02	Cap, Blasting, Special Electric *	AES T1267, AS 49-20	04-2584, 300-500	211-1050-E
11.10	Primer, Percussion Cap	Western No. 3, Battery Cup Primer.		780-5000-E
11.15	Kit, Mine Conversion, Mark 7 Mod. 0	Sk. 109608		540-0700-G
11.16	Kit, Mine Conversion, Mark 8 Mod. 0	Sk. 109609		540-0800-G
12.01	Fuse, Blasting, Time	AS 49-16	04-5464, 700-300 R7EHA	508-8000-E
13.01	Machine, Blasting, Ten Cap	FS W-B-411	04-6472, 500-100	702-1000-E
13.03	Machine, Blasting, Thirty Cap	FS W-B-411	04-6472, 500-300	702-3000-E
14.01	Firing Device, Demolition, Mark 1 Mod. 1	Dwg. 438186		483-0110-E
14.02	Firing Device, Demolition, Mark 6 Mod. 0 with Arming Cell Mk. 1 Mod. 0— (9 min. Delay at 60°F)	Dwg. 416299		483-6100-E
14.03	Firing Device, Demolition, Mark 6 Mod. 0 with Arming Cell Mk. 1 Mod. 1— (15 min. Delay at 60°F)	Dwg. 416299		483-6110-E
14.04	Firing Device, Demolition, Mark 6 Mod. 0 with Arming Cell Mk. 1 Mod. 2— (30 min. Delay at 60°F)	Dwg. 416299		483-6120-E
14.05	Firing Device, Demolition, Mark 6 Mod. 0 with Arming Cell Mk. 1 Mod. 3— (60 min. Delay at 60°F)	Dwg. 416299		483-6130-E
14.06	Firing Device, Demolition, Mark 6 Mod. 0 with Arming Cell Mk. 1 Mod. 4— (90 min. Delay at 60°F)	Dwg. 416299		483-6140-E
14.15	Firing Device, Pressure Type, M1	AED D-2856-1	04-5176, 400-500	486-0100-E
14.16	Firing Device, Pull Type, M1	AED D-2855-1	04-5176, 600-500	487-0100-E
14.17	Firing Device, Release Type, M1	AED D-3961-1	04-5176, 800-500	488-0100-E
14.18	Firing Device, Pull Release Type, M3	AED D-3979-1	04-5176, 500-300	489-0300-E
14.19	Firing Device, Pull Friction, M2	AED D-4273-1	04-5176, 480-200	485-0200-E
14.30	Lighter, Fuse, Friction Type, M1	AS 49-8	04-5896, 500-500	667-2500-E
14.31	Lighter, Fuse, Weatherproof, M2	AED D-4256-1	04-5896, 500-700	667-0200-E
15.10	Timer and Battery Box Mark 3 Mod. 0	Dwg. 393658		930-3000-E
16.01	Firing Device, Demolition, Mark 3 Mod. 0	Dwg. 423577		483-0300-E
16.05	Firing Device, Delay Type, M1	AED D-2871-1	04-5176, 200-300	482-0100-E
16.07	Detonator, 15 Second Delay, M1	AED D-4367-1	04-4200, 500-010	470-0100-E
16.10	Fuze, Detonating, Hand Grenade, M6A4	AD 82-1-31		
17.01	Cord, Detonating, Plain	AS 49-10	04-3736, 500-010 R7EGA	410-2000-E
17.02	Cord, Detonating, Reinforced	Ens. Bickford Co.		410-1000-E
17.03	Cord, Detonating, Wirebound	Ens. Bickford Co.		410-4000-E
21.01	Fuse, Mark 143 Mod. 0			501-4300-E
21.02	Fuse, Mark 143 Mod. 1			501-4310-E
22.05	Booster Mark 13 Mod. 0	NOLS 70955		111-3000-E
31.01	Block, TNT, ½ lb.	Dwg. 437862		076-3000-E
31.02	Block, TNT, 1 lb.	AS 50-13-14	R7EAA	076-4000-E
31.03	Blocks, Demolition, Chain, M1	AED-C 4841-1	04-8776, 500-700	076-0100-E
31.04	Block, Demolition, M2	AD-82-0-87	04-1800, 500-100 R7EQA	076-0200-E
31.05	Block, Demolition, M3	AD-82-0-93	04-1800, 500-200 R7HCA	076-0300-E
31.06	Block, Demolition, M4	AS-AXS-1022	04-1800, 500-300 R7HDA	076-0400-E
31.10	Charge, Demolition, Mark 2 Mod. 0	AS-AXS-1022	04-1800, 500-400 R7HEA	270-2010-E
31.20	Charge, Demolition, Mark 2 Mod. 1	Dwg. 328794		270-2110-E
31.21	Charge, Demolition, Mark 9 Mod. 0	Dwg. 422558		270-9000-E
31.22	Charge, Demolition, Mark 9 Mod. 1	Dwg. 393660		270-9100-E
31.25	Charge, Demolition, Mark 14 Mod. 0	Dwg. 423149		271-4000-E
31.26	Charge, Demolition, Mark 14 Mod. 1	Dwg. 423149		271-4100-E
33.01	Charge, Demolition, Mark 8 Mod. 0	Dwg. 394445		270-8000-E
33.20	Bangalore Torpedo M1, Kit	AD 82-0-84	R7FAB	050-1010-E
34.01	Container, Cavity Charge, Mark 1 Mod. 0	Dwg. 422108		400-0100-E

APPENDIX I

Index Number	Order Unit**	Method of Packing	Packing Data					
			Dimensions Outside			Sq. Ft. Area	Cu. Ft. Volume Outside	Lbs. Wt. Gross
			L	W	H			
11.01		100/ctr, 10 ctrs/ctn, 5 ctns (5000)/wdn bx	1.54	1.08	.65	1.06	1.08	39
11.02		50/fbr bx, 10 bxs, (500)/wdn bx	1.00	.96	.79	.96	.76	24
11.10		100/ctr, 50 ctrs (5000)/wdn bx	1.54	.63	.54	.96	.52	24
11.15								
11.16								
12.01	Feet	5-100 ft rolls/mtl can, 8 cans (4000 ft)/wdn bx	2.25	1.25	1.25	2.81	3.52	75
13.01		30/wdn bx	29.0	20.5	11.0	1.72	1.58	192
13.03		12/wdn bx	32.0	27.0	16.0	6.0	8.0	288
14.01		1/mtl can, 10 cans/fbd etn, 5 ctns (50)/wdn bx	1.83	1.25	.58	1.06	1.4	65
14.03		1/MTL, can						
14.03		1/MTL, can						
14.04		1/MTL, can						
14.05		1/MTL, can						
14.06		1/MTL, can						
14.15		5/etn, 30 ctns (150)/wdn bx	1.08	.84	.71	.76	.64	25
14.16		5/etn, 30 ctns (150)/wdn bx	1.08	.84	.71	.76	.64	25
14.17		4/fbr bx, 20 bxs (80)/wdn bx	2.63	.82	.69	1.8	1.47	41
14.18		5/ctn, 30 ctns (150)/wdn bx	1.09	.84	.71	.77	.65	25
14.19		5/etn, 30 ctns (150)/wdn bx	1.09	.84	.71	.77	.65	25
14.30		10/tube, 250 tubes (2500)/wdn bx						28
14.31		5/bx, 30 bxs (150)/wdn bx	1.13	1.36	1.66	1.53	2.54	25
15.10								
16.01		1/mtl can, 10 cans/fbr etn, 5 ctns (50)/wdn bx	2.0	1.07	.75	1.5	1.61	70
16.05	Carton	10/fbrbd bx, 50 bxs (500)/wdn bx	1.84	1.09	.92	1.69	1.82	55
16.07		10/fbrbd bx, 20 bxs (200)/wdn bx						
16.10		25 fuzes/ctr, 8 ctrs (200)/wdn bx						
17.01	Feet	100-500 ft/ctn						
17.02	Feet	5-100 ft rolls/mtl can, 8 cans (4000 ft)/wdn bx	2.25	1.25	1.25	2.81	3.52	
17.03	Feet	500 ft roll/ctn						
21.01								
21.02								
22.05		80 Boosters/steel bx	1.59	1.09	.84	1.34	1.43	65
31.01		108-1/2 lb blocks/wdn bx	1.48	1.0	.75	1.48	1.11	65
31.02		50/wdn bx						
31.03	Chain	1 Chain 8-2 1/2 lb blocks/Haversack, 2 Haversacks (16)/wdn bx	1.76	1.25	.61	2.20	1.34	62
31.04	Block	8-2 1/2 lb blocks/Haversack, 2 Haversacks (16)/wdn bx	1.76	1.25	.61	2.20	1.34	62
31.05	Block	8-2 1/2 lb blocks/Haversack, 2 Haversacks (16) bx	1.13	0.83	0.85		0.81	44
31.06	Block	104/wdn bx	1.48	1.0	0.67		0.99	61
31.19		1/wdn bx	1.07	.83	.83	.89	.74	
31.20		1/wdn bx	1.33	1.0	1.0	1.33	1.33	76
31.21		1/wdn bx	1.33	1.07	1.07	1.42	1.52	136
31.22		1/wdn bx						
31.25		1/cdbd bx, 24 bxs on pallet	4.0	4.0	1.07	6.34	25.35	1400
31.26		1/cdbd bx, 24 bxs on pallet	4.0	4.0	1.07	6.34	25.35	1400
33.01		25 ft length 3 per bdl	25.0	.04	.04	.93	.04	75
33.20	Box	10/wdn bx	5.28	1.32	.45	6.99	3.13	168
34.01		100 (2 1/4" dia)/wdn bx	2.08	1.06	.83	1.72	1.83	80

UNIT PACKAGE INDEX

Index Number	Official Designation	Specification or Dwg. No.	Army Code Number	Navy Code Number
34.03	Container, Cavity Charge, Mark 3 Mod. 0	Dwg. 422394		400-0300-E
34.10	Cutter, Cable and Chain, Mark 1 Mod. 1	Dwg. 439200		430-1100-E
34.19	Charge, Shaped, M1	AED D2843-1	R7EVA-R7EVB-R7EWA	307-0100-E
34.20	Charge, Shaped, M2	AED D3803-1	R7HAA	307-0200-E
34.21	Charge, Shaped, M3		R7EVA	307-0300-E
35.01	Mine, Antitank, H.E., M1A1	AOD 82-0-42	R7AFA	
			R7AIA	
35.02	Mine, Antitank, H.E., M5	AOD 82-0-89	R7AHA	
35.03	Mine, Antitank, H.E., LIGHT M7	AOD 82-0-114	R7AQA	
35.10	Mine, Antitank, Practice, M1B1	AOD 82-0-43	R7AOA	
36.01	Mine, Antipersonnel, M2A1	AD 82-0-71	R7AKA	
36.02	Mine, Antipersonnel, M3	AD 82-0-79	R7AEA	
36.08	Mine, Antipersonnel Practice M8	AD 82-0-112	R7APA	
36.10	Flare, Trip, M48	AOD 78-0-45		80540-B
36.11	Flare, Trip, M49	AOD 78-0-43		80550-B
36.20	Grenade, Hand Offensive, Mark IIIA2	AOD 82-0-86		
38.01	Thermit Igniter Mark 1 Mod. 0	Dwg. 394321		908-6100-E
38.02	Thermit Burning Charge Mark 1 Mod. 0	Dwg. 342966		908-0100-E
38.04	Thermit Charge, Underwater, Mark 2 Mod. 1	Dwg. 344593		908-0210-E
38.10	Thermit Unit, 10 lb.	ACW 257-233		908-7000-E
39.01	Outfit, Demolition, Mark 104 Mod. 1 4 Demolition Charges Mark 6 4 1/2 lb. Auxiliary Charges/ml cap 1 Priming Assembly			
39.02	Outfit, Demolition, Mark 108 Mod. 0 (No code number exists for complete Outfit, Demolition, Mark 108 Mod. 0, but it can be ordered by code numbers for items listed below)	Sk. 102900		741-0410-E
	1 Timer and Battery Box Mark 3 Mod. 0 (15.10)	Dwg. 393558		930-3000-E
	3 Demolition Charges Mk. 2 Mod. 0 (31.19)	Dwg. 328794		270-2010-E
	8 Caps Blasting, Special Electric (11.02)	AS 49-20		211-1050-E
	1 Box, Electric Cap (43.10)	Dwg. 394760		138-4000-E
	600 ft. Cable, Demolition, Single Conductor (41.01) Required for operation but not furnished:	FS 15-W-46000		172-6010-E
	8 No. 6 Dry Cells (Supply Depot Item)			
39.15	Destructor AN M1	AD 82-3-340	R7ELA	465-0100-E
39.16	Destructor AN M3 8 ANM3A1	AOD 82-3-392	R7ETA-R7EKX	465-0300-E
41.01	Cable, Demolition, Single Conductor			172-6010-E
41.02	Wire, Firing, Double Conductor, Army	AES 49-11	15-9215, 500-340	963-4500-E
41.03	Wire, Firing, Double Conductor, Army, Lightweight	AES T-1832A		963-4520-E
41.04	Cable, Demolition, Double Conductor	OS 718		172-6020-E
41.05	Wire, Firing, Double Conductor, Navy, Lightweight	OS 1448	04-7624, 500-070 RI-39A	963-4530-E
41.10	Reel, Army Firing Wire	AD D-1445-3		823-4400-E
41.11	Reel, Wire, Firing RI39A	SC-D-4700		823-4500-E
41.15	Reel Box Mark 2 Mod. 0	Dwg. 180301	04-5608, 500-500	137-2000-E
42.01	Galvanometer, Blasting	FS W-B-411		880-8600-E
42.04	Crimper, Cap, Waterproof		04-4024, 500-505	422-0300-E
42.05	Crimper, Cap M2	AED C-4246-1		
42.20	Compound, Cap Sealing	DuPont Co.	52-2774, 500-050	220-9000-E
42.40	Adapter, Priming, M1	AS 49-22	04-1070, 500-200	030-0100-E
43.01	Chest, Demolition, Platoon	AED D-1406	04-3448, 500-500	367-1610-E
43.03	Box, Charge	Dwg. 180309		132-1800-E
43.10	Box, Electric Cap	Dwg. 394760		138-4000-E
43.11	Box, Nonelectric, Cap	AED A-5253	04-2152, 200-100	138-3900-E
43.20	Haversack	AD 76-1-533		570-0000-E

APPENDIX I

Index Number	Order Unit**	Method of Packing	Packing Data					
			Dimensions Outside			Sq. Ft. Area	Cu. Ft. Volume Outside	Lbs. Wt. Gross
			L	W	H			
34.03		50 (3" dia)/wdn bx	1.50	1.50	1.0	1.50	2.25	25
34.10								
34.19								
34.20		3 chgs/wdn bx						
34.21		1 chg/wdn bx	2.17	.90	.90	1.95	1.75	95
35.01		5/wdn bx	2.18	.83	.90	1.81	1.63	74
35.02		4/wdn bx	2.24	.95	1.01	2.12	2.15	78
35.03		8/steel bx	1.59	.92	.67	1.05	.97	
35.10		5/wdn bx	2.07	.83	.92	1.71	1.56	37
36.01		1/ctn, 10 ctns (10)/wdn bx	2.67	1.10	.79	2.93	2.31	94
36.02		6/wdn bx	1.49	.72	.75	1.08	.81	74
36.08								
36.10		4 ctns/wdn bx	1.25	1.07	.92	1.14	1.21	42
36.11		16/wdn bx	1.58	1.03	.83	1.31	1.35	46
36.20		50/wdn bx						
38.01		1/mtl can, 12 cans/ctn, 24 ctns (288)/wdn bx	2.58	1.75	1.25	3.23	5.64	150
38.02		4/wdn bx						
38.04		4/wdn bx						125
38.10								
39.01		1 complete Outfit (6 cans)/wdn bx						
39.02		1/wdn bx (when ordered for Demolition Outfit Mark 108, Mod. 0)						
		1/wdn bx 3 bxs						
		1/wdn bx						
		1 per wdn Spool						
39.15		10/ctn, 10 inner ctns/outer ctn, 20 outer ctns (2000)/wdn bx	1.92	1.58	1.07	2.05	3.25	89
39.16		10/ctn, 10 ctns (200)/wdn bx	1.58	1.44	1.28	2.02	2.90	108
41.01	Feet							
41.02	Feet	1-500 ft coil						10
41.03	Feet	1-500 ft coil/wdn bx						30
41.04	Feet	1-1000 ft reel/wdn bx						147
41.05	Feet	1-1000 ft coil/wdn bx						65
41.10	Feet	Packed with 500 feet OS 718						
41.11								
41.15		1/wdn bx	2.0	1.50	1.58	3.0	4.74	180
42.01								
42.04								
42.05		6/ctn						
42.20	Can	1/2 pt cans						
42.40		10/fbd bx 500 bxs (5000)/wdn bx						17
43.01		1/wdn bx	2.12	1.5	.88	2.12	3.19	45
43.03								
43.10								
43.11								
43.20								

BAL —BuOrd. Allowance List
 DWG —BuOrd. Drawing
 SK —BuOrd. Sketch
 NOLS —Naval Ordnance Laboratory Sketch
 ACW —Army Chemical Warfare
 AD —Army Drawing
 AED —Army Engineer Drawing
 AES —Army Engineering Specification
 AOD —Army Ordnance Drawing
 AS —Army Specification
 FS —Federal Specification

* —Box Marking "Will Detonate Composition C"
 ** —"Each" Unless Otherwise Specified
 BX —Box
 CNTR —Container
 CTN —Carton
 FBD —Fiber Board
 FBR —Fiber
 MTL —Metal
 WDN —Wooden
 / —Per

RESTRICTED

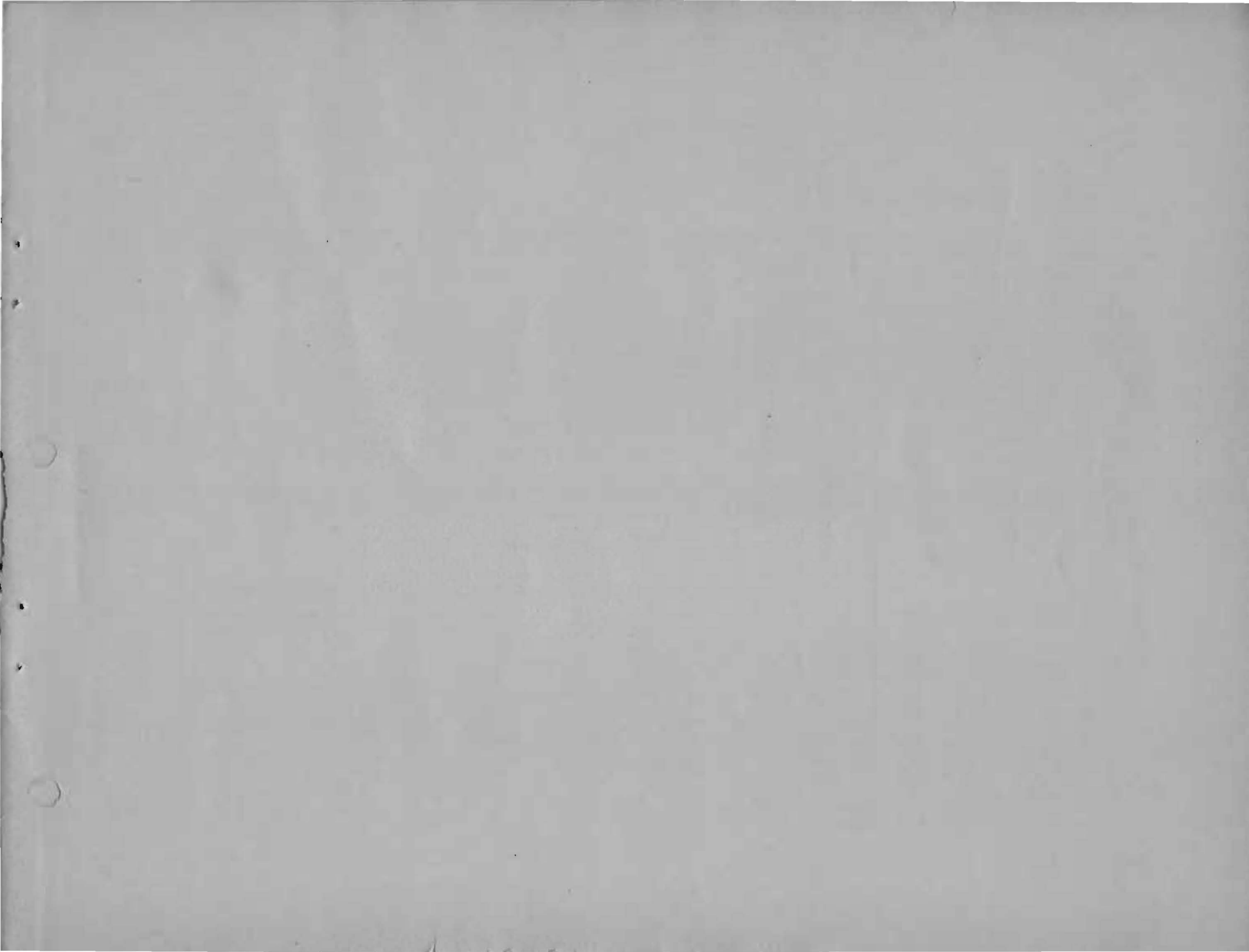

CHARACTERISTICS CHART

The functional characteristics of Initiators, Boosters and Fuzes, and Charges listed in this publication are shown here; with the explosive process from the application of an external initiating impulse to the completed detonation of a main charge divided into the following stages:

ACTUATION

Items filling this column provide means for the initiation of an explosive train by releasing a firing pin, or by generating an electric current, when actuated by the application or release of pressure, tension or torsion.

MECHANICAL DELAY

Items filling this column provide either a fixed or adjustable mechanical time delay between the time of actuation and first flash. Where a line is drawn across this column no mechanical delay is provided and none can be attached.

FIRST FLASH

Items filling this column provide, when ignited by friction, percussion, or electric current; a flash of flame which will ignite a powder train or cause detonation of a priming explosive charge.

BURNING DELAY

Items filling this column provide either a fixed or adjustable time delay between the First Flash and the First Detonation. Where a line is drawn across this column no burning delay is provided and none can be attached.

FIRST DETONATION

Items where this column is filled provide the first detonation in the explosive train of sufficient force to detonate boosters or main charges.

WILL DETONATE

These columns indicate the strength of detonation of Initiators, Boosters, and Fuzes where Main Charges are properly installed.

Items which will detonate Detonating Cord will also detonate charges fitted with tetryl boosters.

APPENDIX II

Items which show that they will detonate Pressed TNT also will directly detonate granular TNT or flaked TNT boosters and all the other commonly used demolition explosives except Composition C.

Items which will detonate Composition C will detonate any of the explosives generally used in demolition without the aid of boosters.

MAIN CHARGE

The general nature, but not the explosive force of the charges listed in Chapter III is indicated in this column, which replaces the "Will Detonate" column used for items in Chapters I and II.

Charges which produce an actual explosion of some force are indicated by solid red bars.

Charges which produce intense heat for demolition by burning are indicated by a bar of wavy red lines.

Charges which produce illumination or a smoke puff for spotting or practice are indicated by a dotted red line.

CHARACTERISTICS CHART

NO.	DESCRIPTION	ACTUATION	MECHANICAL DELAY	FIRST FLASH	BURNING DELAY	FIRST DETONATION	WILL DETONATE		
							DET'G CORD	PRESSED TNT	COMP. "C"
11.01	CAP, BLASTING, SPECIAL NONELECTRIC								
11.02	CAP, BLASTING, SPECIAL ELECTRIC								
11.10	PRIMER, NO. 3 CUP								
11.15	KIT, MINE CONVERSION MARK 7 MOD O								
11.16	KIT, MINE CONVERSION MARK 8 MOD O								
12.01	FUSE, BLASTING, TIME								
13.01	MACHINE, BLASTING, TEN CAP								
13.03	MACHINE, BLASTING, THIRTY CAP								
14.01	FIRING DEVICE, DEMOLITION, MARK 1 MOD 1								
14.02 to 14.06	FIRING DEVICE, DEMOLITION, MARK 6 AND MODS								
14.15	FIRING DEVICE, PRESSURE TYPE, M1A1								
14.16	FIRING DEVICE, PULL TYPE, M1								
14.17	FIRING DEVICE, RELEASE TYPE, M1								
14.18	FIRING DEVICE, PULL RELEASE TYPE, M3								
14.19	FIRING DEVICE, PULL FRICTION, M2								
14.30	LIGHTER, FUSE, FRICTION TYPE, M1								
14.31	LIGHTER, FUSE, WEATHER PROOF, M2								
15.10	TIMER AND BATTERY BOX, MARK 3 MOD O								

APPENDIX II

NO.	DESCRIPTION	ACTUATION	MECHANICAL DELAY	FIRST FLASH	BURNING DELAY	FIRST DETONATION	WILL DETONATE		
							DET'G. CORD	PRESSED TNT	COMP. "C"
16.01	FIRING DEVICE, DEMOLITION, MARK 3 MOD O								
16.05	FIRING DEVICE, DELAY TYPE, M1								
16.06	15 SECOND DELAY DETONATOR M1								
16.10	FUZE, DETONATING, HAND GRENADE, M6A4								
17.01	CORD, DETONATING, PLAIN								
17.02	CORD, DETONATING, REINFORCED								
17.03	CORD, DETONATING, WIREBOUND								
21.01	FUZE, DEMOLITION, MARK 143 MOD O								
21.02	FUZE, DEMOLITION, MARK 143 MOD 1								
22.05	BOOSTER MARK 13 MOD O								
							MAIN CHARGE		
31.01	BLOCK, TNT, 1/2 LB.								
31.02	BLOCK, TNT, 1 LB.								
31.03	BLOCKS, DEMOLITION, CHAIN, M1								
31.04	BLOCK, DEMOLITION, M2								
31.05	BLOCK, DEMOLITION, M3								
31.06	BLOCK, DEMOLITION, M4								
31.19	CHARGE, DEMOLITION, MARK 2 MOD O								

RESTRICTED

CHARACTERISTICS CHART

NO.	DESCRIPTION	ACTUATION	MECHANICAL DELAY	FIRST FLASH	BURNING DELAY	FIRST DETONATION	MAIN CHARGE
31.20	CHARGE, DEMOLITION, MARK 2 MOD 1						[Red Striped Area]
31.21	CHARGE, DEMOLITION, MARK 9 MOD 0						
31.22	CHARGE, DEMOLITION, MARK 9 MOD 1						
31.25	CHARGE, DEMOLITION, MARK 14 MOD 0						
31.26	CHARGE, DEMOLITION, MARK 14 MOD 1						
33.01	CHARGE, DEMOLITION, MARK 8 MOD 0						[Red Striped Area]
33.20	BANGALORE TORPEDO M1, KIT						
34.02	CONTAINER, CAVITY CHARGE, MARK 1 MOD 0						
34.03	CONTAINER, CAVITY CHARGE, MARK 3 MOD 0						
34.10	CUTTER, CABLE AND CHAIN, MARK 1 MOD 1						
34.19	CHARGE, SHAPED, M1						[Red Striped Area]
34.20	CHARGE, SHAPED, M2						
34.21	CHARGE, SHAPED, M3						
35.01	MINE, ANTITANK, M1A1	[Red Striped Area]	[Red Striped Area]	[Red Striped Area]	[Red Striped Area]	[Red Striped Area]	[Red Striped Area]
35.02	MINE, ANTITANK, M5	[Red Striped Area]	[Red Striped Area]	[Red Striped Area]	[Red Striped Area]	[Red Striped Area]	
35.03	MINE, ANTITANK, LIGHT, M7	[Red Striped Area]	OR	[Red Striped Area]	[Red Striped Area]	[Red Striped Area]	[Red Striped Area]
			OR				

APPENDIX II

NO.	DESCRIPTION	ACTUATION	MECHANICAL DELAY	FIRST FLASH	BURNING DELAY	FIRST DETONATION	MAIN CHARGE
35.10	MINE, ANTITANK, PRACTICE, M1B1	[Red Bar]	[Red Bar]	[Red Bar]	[Red Bar]	[Red Bar]	[Red Dotted Pattern]
36.01	MINE, ANTIPERSONNEL, M2A1	[Red Bar]	[Red Bar]	[Red Bar]	[Red Bar]	[Red Bar]	[Red Dotted Pattern]
36.02	MINE, ANTIPERSONNEL, M3	[Red Bar]	[Red Bar]	[Red Bar]	[Red Bar]	[Red Bar]	[Red Dotted Pattern]
36.08	MINE, ANTIPERSONNEL, PRACTICE M8	[Red Bar]	[Red Bar]	[Red Bar]	[Red Bar]	[Red Bar]	[Red Dotted Pattern]
36.10	FLARE, TRIP, M48	[Red Bar]	[Red Bar]	[Red Bar]	[Red Bar]	[Red Bar]	[Red Dotted Pattern]
36.11	FLARE, TRIP, M49	[Red Bar]	[Red Bar]	[Red Bar]	[Red Bar]	[Red Bar]	[Red Dotted Pattern]
36.20	GRENADE, HAND OFFENSIVE, MARK IIIA2	[Red Bar]	[Red Bar]	[Red Bar]	[Red Bar]	[Red Bar]	[Red Dotted Pattern]
38.01	THERMIT IGNITER MARK 1 MOD O	[Red Bar]	[Red Bar]	[Red Bar]	[Red Bar]	[Red Bar]	[Red Wavy Pattern]
			OR				[Red Wavy Pattern]
38.02	THERMIT BURNING CHARGE MARK 1 MOD O	[Red Bar]	[Red Bar]	[Red Bar]	[Red Bar]	[Red Bar]	[Red Wavy Pattern]
38.04	THERMIT CHARGE, UNDERWATER, MARK 2 MOD 1	[Red Bar]	[Red Bar]	[Red Bar]	[Red Bar]	[Red Bar]	[Red Wavy Pattern]
38.10	THERMIT UNIT, 10 LB.	[Red Bar]	[Red Bar]	[Red Bar]	[Red Bar]	[Red Bar]	[Red Wavy Pattern]
39.01	OUTFIT, DEMOLITION, MARK 104 MOD 1	[Red Bar]	[Red Bar]	[Red Bar]	[Red Bar]	[Red Bar]	[Red Wavy Pattern]
39.02	OUTFIT, DEMOLITION, MARK 108 MOD O	[Red Bar]	[Red Bar]	[Red Bar]	[Red Bar]	[Red Bar]	[Red Wavy Pattern]
39.15	DESTRUCTOR AN-M1	[Red Bar]	[Red Bar]	[Red Bar]	[Red Bar]	[Red Bar]	[Red Wavy Pattern]
39.16	DESTRUCTOR AN-M3	[Red Bar]	[Red Bar]	[Red Bar]	[Red Bar]	[Red Bar]	[Red Wavy Pattern]

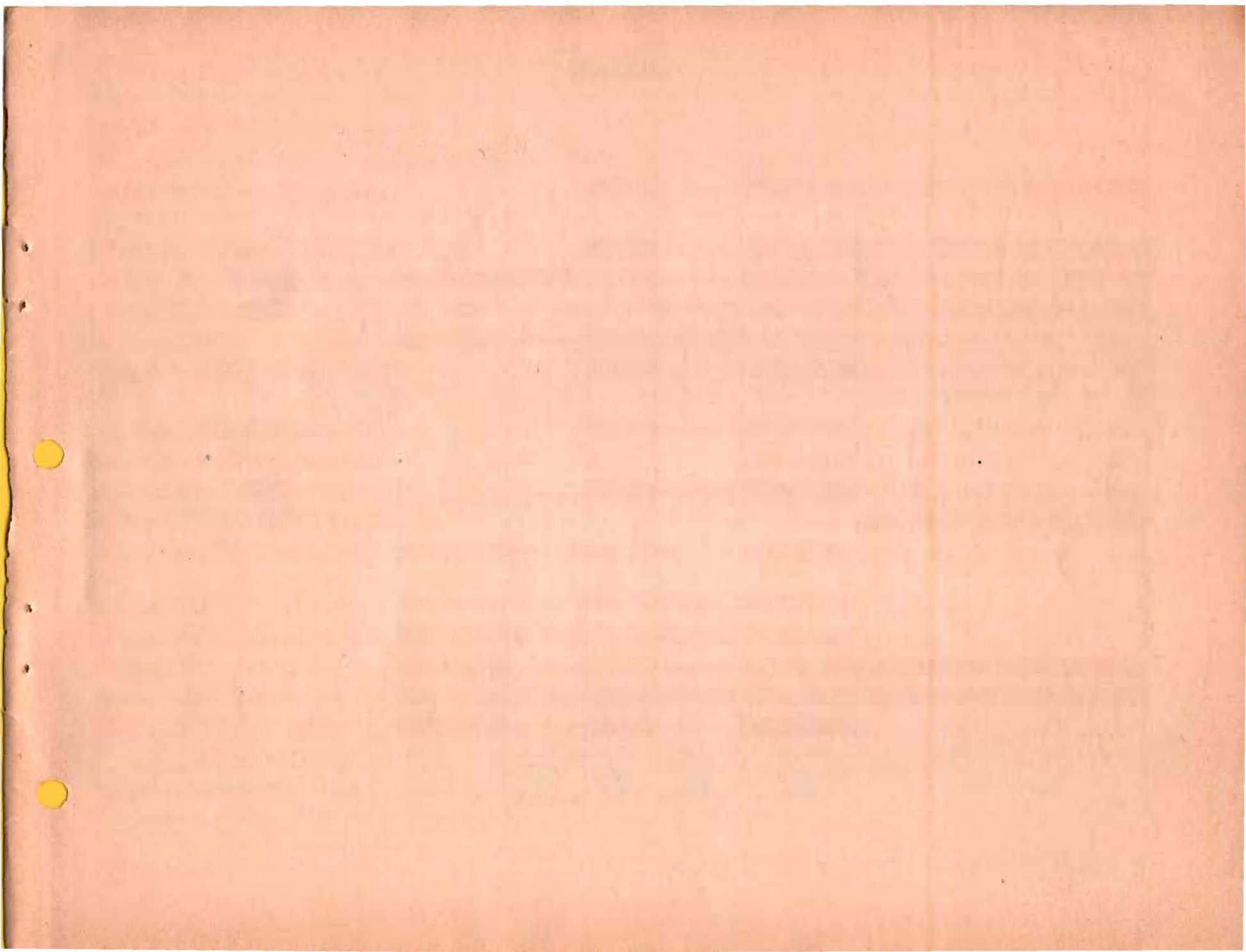

Demolition equipment in the past has been independently developed by a number of different agencies in the Navy, the Marine Corps, Army Ordnance, and Army Engineers largely for specific and limited uses. Some equipment has been modified for demolition use from material designed for entirely different purposes. This has been particularly true of earlier developments because of the requirements of rapidly expanding demolition activities.

More recently the urgent problem of interchangeability of demolition equipment has been met by informal cooperation between the design agencies of the Navy and Army. A joint Army-Navy Specification entitled "Demolition Equipment Standards" is now being prepared to aid in the formal correlation of design of all interchangeable components of demolition equipment. As these standards and others are developed they will be described in revisions of this Appendix under the following divisions:

NOMENCLATURE STANDARDS

There has been considerable confusion and misunderstanding in field usage and official communications within and between the various branches of the armed forces because of the lack of definite accepted official terminology for demolition work. As joint Army-Navy agreements are reached on such terminology, the names and expressions used in connection with demolitions will be clearly defined in revisions of this section.

DESIGN STANDARDS

To provide the utmost flexibility in assembly and operation of demolition charges, standardized dimensions and tolerances must be maintained on all interchangeable components. The "Demolition Equipment Standards" joint Army-Navy Specification now under preparation will officially establish dimensions on certain vital parts of detonating assemblies. This section will include both of-

icial Army-Navy drawings and proposed standard drawings on demolition equipment.

INTERCHANGEABLE ASSEMBLIES

Here are illustrated and described the general types of assemblies of demolition material using the interchangeable parts which have been standardized. No attempt has been made to show all possible combinations, but assemblies useful for many conditions will be suggested by the typical illustrations and descriptions given here.

STANDARDS

1 Striker Case Thread

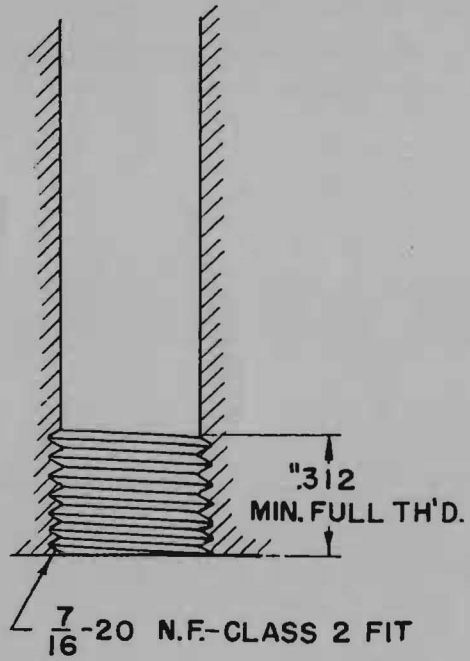

2 Primer, Percussion Cap

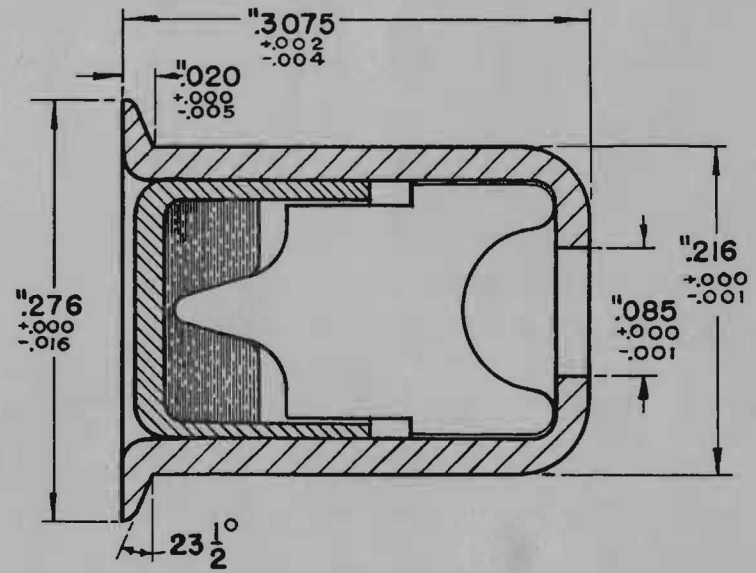

3 Base, Coupling

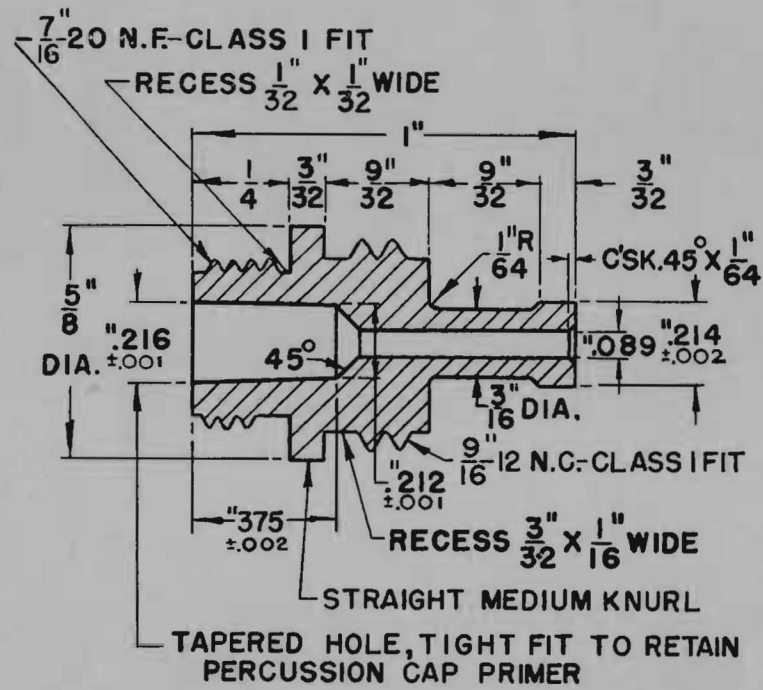

STANDARDS

4 Cap, Blasting, Special, Nonelectric

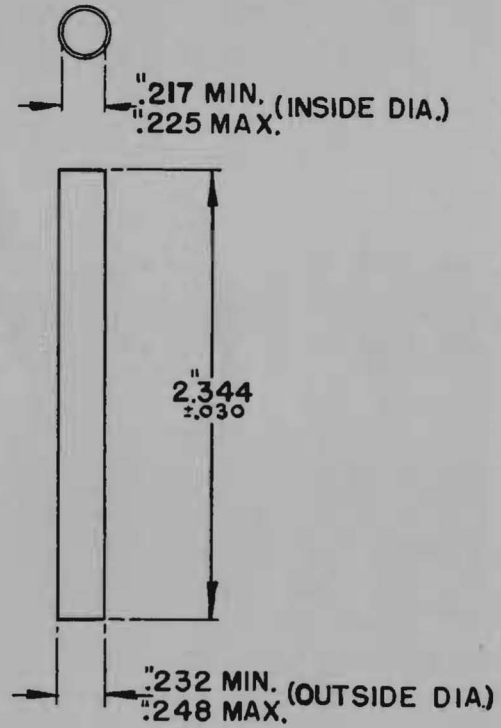

5 Cap, Blasting, Special, Electric

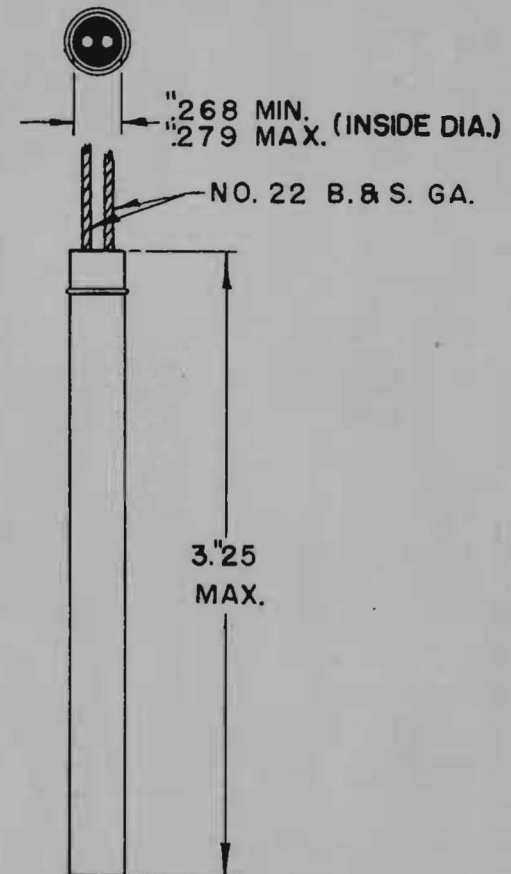

6 Threaded Activator Well

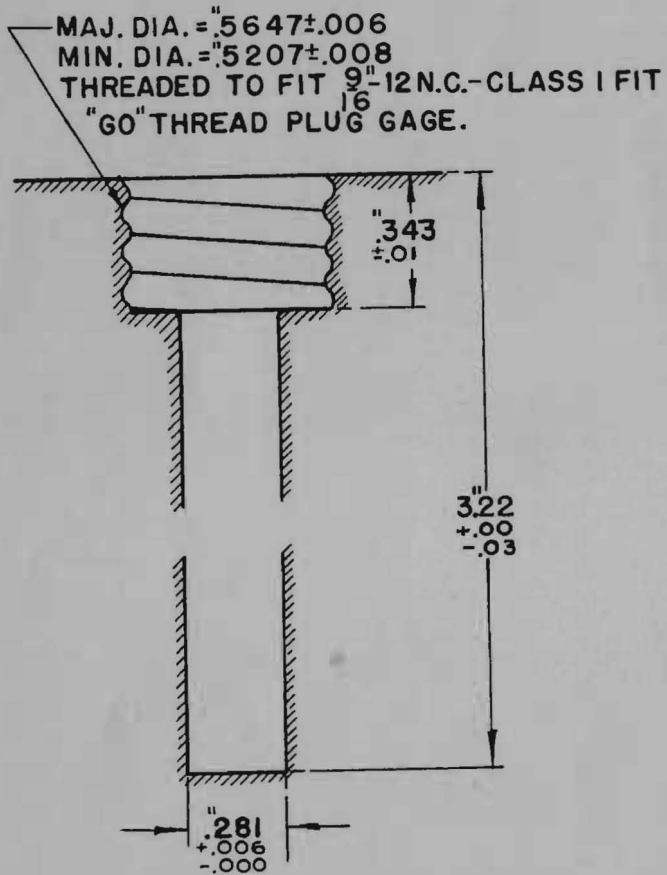

7 Adapter, Priming

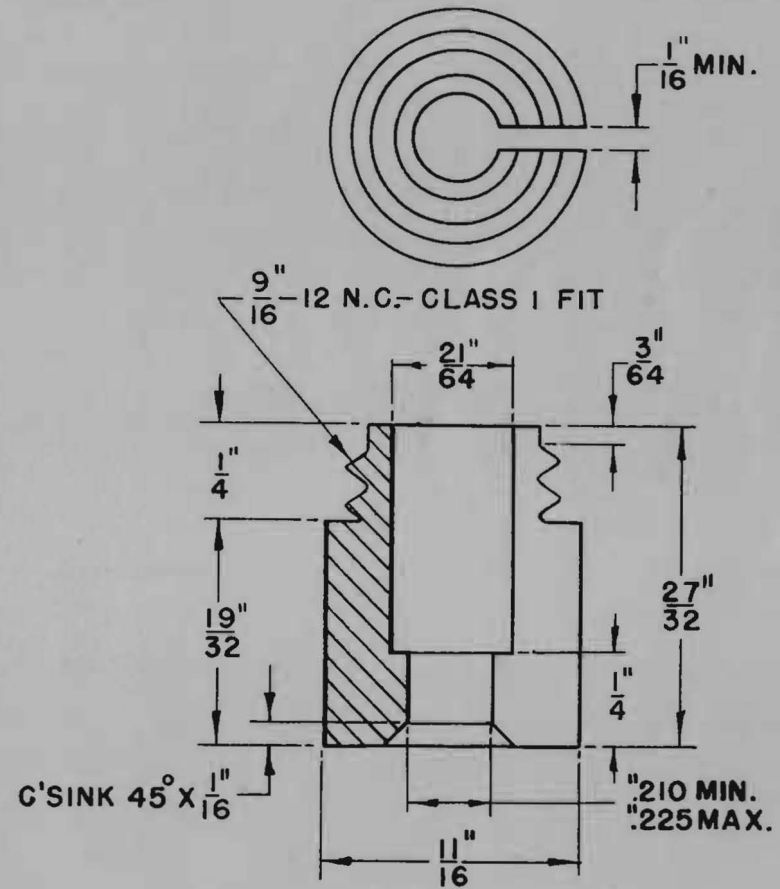

Mechanical Detonating Assemblies

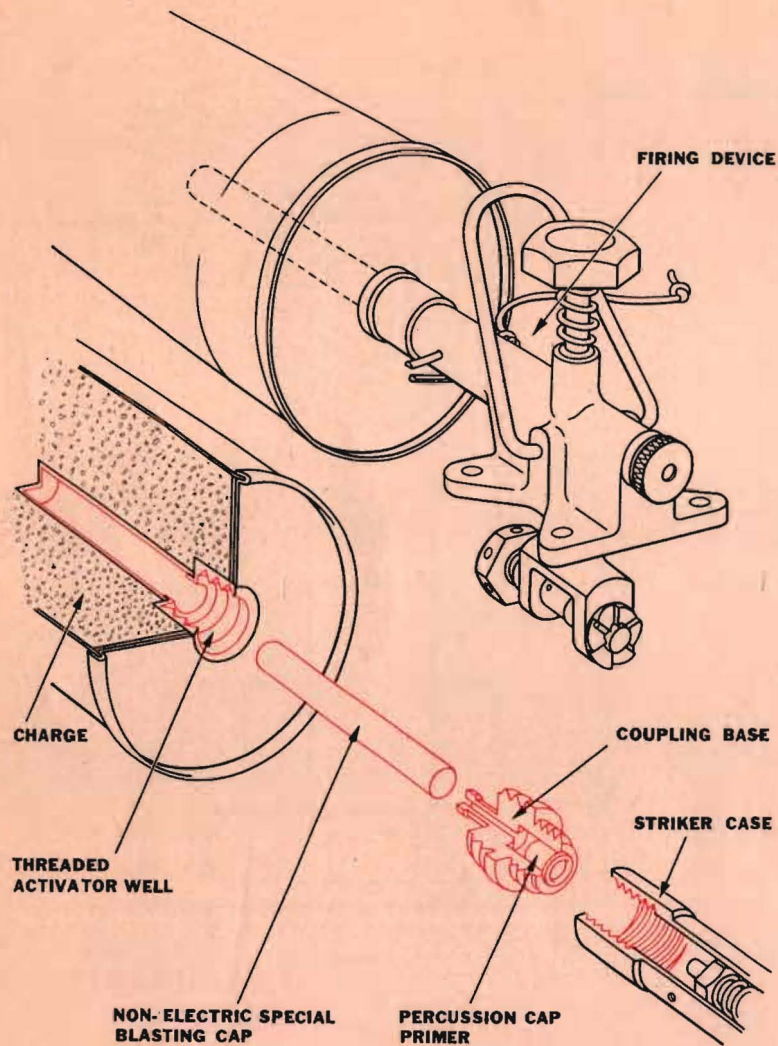

Charges fitted with the Threaded Activator Well (Design Standard 6) can be detonated by application or release of pressure or tension, when assembled in the manner shown. One of the firing devices

listed in Sections 14 and 16 which provides an appropriate means of actuation, and is fitted with the Coupling Base (Design Standard 3), should be selected.

Crimp a Nonelectric Special Blasting Cap (Design Standard 4) over the end of the Coupling Base with a Cap Crimper as shown, and screw the assembly into the Threaded Activator Well. The charge assembly will be ready for detonation and armed by the removal of the safety pins in the firing device.

Some firing devices and all detonators classed as firing devices are fitted with a special non-removable coupling base which will screw into the Threaded Activator Well. Several of these devices also provide a self-contained detonating charge which replaces the Non-electric Special Blasting Cap. These special firing devices can be utilized as pre-assembled components in interchangeable assemblies.

Booster Mark 13 (22.05) and several of the Main Charges in Chapter 3 are fitted with a special non-removable coupling which will screw into the Striker Case Thread (Design Standard 1). These charges can be detonated by firing devices fitted with the Coupling Base. Remove the Coupling Base furnished with the firing device and screw the device onto the special base on the charge.

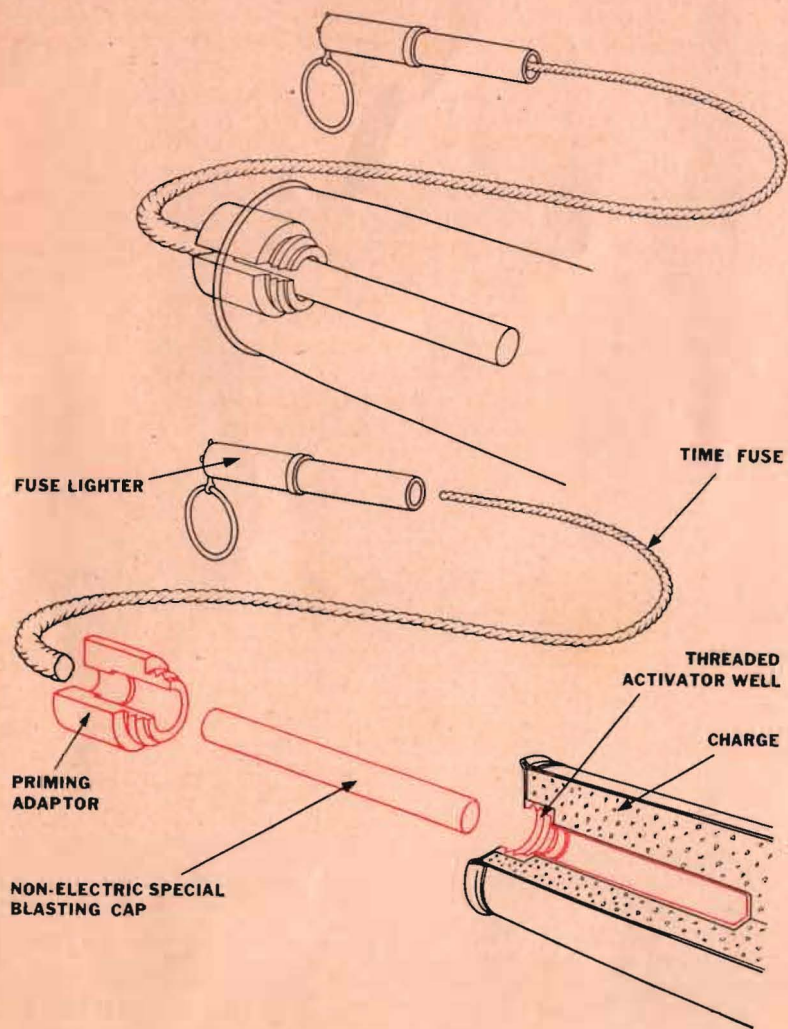

Charges fitted with the Threaded Activator Well (Design Standard 6) can be detonated with any desirable time delay when assembled in the manner shown.

A square-cut fresh end of Fuse, Blasting, Time (12.01) is pushed as far as possible into the open end of the Nonelectric Special Blasting Cap (Design Standard 4) and crimped in place by a Cap Crimper. Insert the cap in the Threaded Activator Well and secure it in place as shown with the Priming Adaptor (Design Standard 7). The charge assembly will be ready for detonation when the time fuse is properly ignited by the Lighter, Fuse, Friction Type, M1, the Lighter, Fuse, Weatherproof M2 or by a safety match.

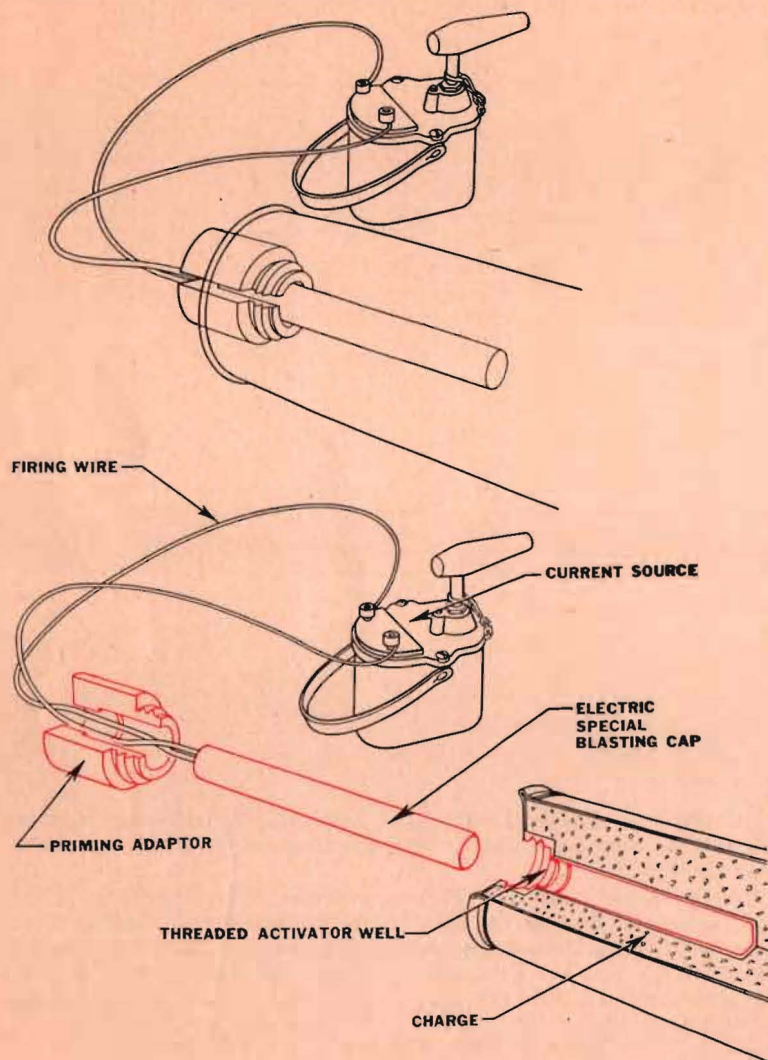

Charges fitted with the Threaded Activator Well (Design Standard 6) can be detonated by an electric current when assembled in the manner shown.

Insert an Electric Special Blasting Cap (Design Standard 5) in the Threaded Activator Well and secure it in place as shown with a Priming Adaptor (Design Standard 7). The charge assembly will be ready for detonation when the blasting cap is connected to a Machine, Blasting (33.01 or 33.03), the Timer and Battery Box Mark 3 Mod. 0 (15.01), or other source of electric current.

The military publications referenced under each item description, and others dealing with various phases of demolition and demolition materials are listed here according to their origin and publication number. Most of these publications have been widely distributed and should be readily available, and all which are not may be obtained by addressing requests to the nearest Bureau of Ordnance publications distribution center. Requests should be addressed, Attention: OrdPubSubCen at the following commands: Comdt and Supt., NavGun, NYd, Washington 25, D. C.; Comdt., NYd, Mare Island, California; CinC OrdPubSubCen, NSD, Pearl Harbor; ComSerFor, Seventh Fleet, P.P.O., San Francisco. The following types of publications are listed:

NAVY

Ordnance Pamphlets, Ordnance Technical Instructions, Ordnance Handling Instructions, and Bureau of Ordnance Circular letters as well as publications of other bureaus in the Navy Department which apply to demolition, are briefly described.

ARMY

Field Manuals, Technical Manuals, Information Bulletins, and Technical Bulletins issued by the United States Army on demolition materials are briefly described.

COMMERCIAL

Commercial publications which are of sufficient value to have been distributed to military activities are briefly described.

NAVY PUBLICATIONS

ORDNANCE PAMPHLETS

OP 4 "AMMUNITION"—Restricted—158 pages. Instructions for the Naval Service. This publication covers instructions governing the care, preservation, stowage, inspection and test of service explosives and general information about ammunition.

OP 741 "DEMOLITION CHARGE OUTFIT"—Restricted—31 pages. Describes the construction and operation of Demolition Outfit Mk. 102 which consists primarily of the Reel Box Mark 2 (41.15) Box, Charge, (43.03), several Charge, Demolition Mark 2 Mod. 0 (31.19) several Block, TNT, Pound (31.01); and miscellaneous equipment which provides an assembly of demolition equipment for clearance of wreckage and general shipboard use.

OP 823 "DEMOLITION OUTFIT MARK 3"—Restricted—17 pages. Describes the construction and operation of standard depth charges fitted with Kit, Mine Conversion, Mark 7 Mod. 0 (11.15) or Mark 8

Mod. 0 (11.16) when installed aboard merchant vessels for scuttling. OP 952 "DEMOLITION OUTFIT MARK 7"—Restricted—4 pages—Describes construction and operation of Kit, Mine Conversion, Mark 7 Mod. 0 (11.15) or Mark 8 Mod. 0 (11.16) in converting 300 and 600 lb. depth charges for demolition use or to controlled mines.

OP 995 "DEMOLITION OUTFIT MARK 104 AND DESTROYER AN-M3"—Confidential—11 pages. Describes the construction and operation of Outfit, Demolition Mark 104 (39.01) and Destroyer AN-M3 (39.16) for the demolition of secret and confidential equipment aboard ship.

OP 1012 "DEMOLITION OUTFIT MARK 108"—Restricted—5 pages. Describes the construction and operation of OUTFIT, DEMOLITION Mark 108 (39.02) for scuttling submarines.

OP 1120 "CARE OF AMMUNITION AT ADVANCED BASES"—Restricted—34 pages. Instructions for handling, stowage and care of ammunition, explosives, ammunition details, etc., at temporary advanced bases and at overcrowded established advanced bases.

OP 1147 "DEMOLITION OUTFIT MARK 119"—Confidential—9 pages. Describes the construction and operation of the Outfit, Demolition Mark 119 (33.10), the "Reddy Fox" charge.

OP 1203 "U. S. NAVY CAVITY CHARGES"—Restricted—11 pages. Contains an elementary description of the cavity charge effect and the construction and use of Container, Cavity Charge Mark 1 (34.01), Mark 2 (34.02), and Mark 3 (34.03).

EXPLOSIVES RESEARCH MEMORANDUM No. 10—Confidential—9 pages. Table of Military Explosives. A summary of the properties of the more important high explosives which are in use by the Navy or with which naval personnel may come into contact. Part 1, Description and Storage Characteristics, Part 2, Sensitivity and Effectiveness.

ORDNANCE CIRCULAR LETTERS

OCL A4-42—Confidential. Describes uses for, and proper handling of, Destroyer AN-M1 (39.15) and AN-M3 (39.16).

OCL A51-43—Confidential. Lists components of, and describes distribution for, demolition outfits for destruction of confidential and secret equipment aboard ship.

OCL A78-43—Confidential. Lists components of, and distribution for, Outfit, Demolition, Mark 108 (39.02).

OCL XII-43—Confidential. Complete bibliography of Ordnance publications containing safety regulations for ammunition, bombs, depth charges, mines, torpedoes warheads, fuses and explosives.

PUBLICATIONS INDEX

OCL AV4-44—Restricted. Describes safety precautions for handling Destructor AN-M1 (39.15) and AN-M3 (39.16).

OCL A19-44—Restricted. Instructions for the proper handling of ammunition by ship's personnel at Naval shore activities.

OCL A55-44—Restricted. Lists and briefly describes U. S. Naval Demolition Equipment with drawing and specification numbers.

ORDNANCE TECHNICAL INSTRUCTIONS

OTI A2-44—Restricted. Describes the construction and operation of Firing Device, Demolition Mark 1. Similar to Firing Device, Demolition Mark 1 Mod. 1 (14.01).

OTI M1-44—Restricted. Describes the construction and operation of Cable and Chain Cutter Mark 1; similar to Cutter, Cable and Chain Mark 1 Mod. 1 (34.10).

ORDNANCE HANDLING INSTRUCTIONS

OHI A4-44—Restricted. Describes the construction and use of Firing Device, Demolition, Mark 3 (16.10).

PASSIVE DEFENSE HANDBOOK NO. 8 (Bureau of Yards and Docks)—“DEMOLITION AT NAVAL SHORE ACTIVITIES.” Restricted complete guide for the use of demolition material in the destruction of structures, stores, facilities or equipment.

ARMY PUBLICATIONS

FIELD MANUALS

FM 5-25 “EXPLOSIVES AND DEMOLITION”—Restricted—122 pages. Basic manual for all Army Engineer demolition activities—describes Army demolition equipment, handling regulations, preparation of charges, calculation of charges and general procedures.

FM 5-30 “OBSTACLE TECHNIQUE”—Restricted—250 pages. Describes the construction and employment of antitank mines and mine fields, antipersonnel mines and booby traps, and demolition procedures for passage of military obstacles.

APPENDIX IV

FM 5-31 “LAND MINES AND BOOBY TRAPS”—Restricted—400 pages. Complete catalog of U. S. Army, British, French, German, Hungarian, Italian, and Japanese antitank and antipersonnel mine construction, as well as tactical usage and operating procedure.

TECHNICAL MANUALS

TM 9-1940 “LAND MINES”—Restricted—51 pages. Describes the construction and operation of Army antitank and antipersonnel mines, Bangalore Torpedoes, and demolition materials.

INFORMATION BULLETINS

IB 98—Restricted—29 pages. Describes the method of construction and usage of improvised electrical firing devices in antipersonnel mines and booby traps.

TECHNICAL BULLETINS

TB ENG. 7—Restricted—10 pages. Describes methods of using explosives to reduce the amount of pick work required to excavate gun emplacements.

TB ENG. 8, “METHODS OF PASSING UNDER WATER AND BEACH OBSTACLES.”—Confidential—69 pages. Reviews amphibious doctrine, describes typical obstacles likely to be encountered, and describes in detail the most recent developments as well as early techniques for the clearance of underwater and beach obstacles with the use of Army demolition materials.

TB ENG. 17 “REDDY FOX CHARGE”—Confidential—23 pages. Describes the construction, operation and tactical employment of the “Reddy Fox” Charge; **Outfit, Demolition Mark 119 (33.10).**

TB ENG. 28—3 pages. Describes the construction and use of **Crimper, Cap, M2 (42.05).**

TB ORD 51 “DESTRUCTORS AN-M1, M2, M3”—Restricted—4 pages. Describes the construction and operation of **Destructor AN-M1 (39.15) and AN-M2 (39.16).**

PUBLICATIONS INDEX

APPENDIX IV

TB 5-25 "WEATHERPROOF FUSE LIGHTER M2" Restricted—3 pages. Describes the construction and operation of **Lighter, Fuse, Weatherproof, M2 (14.31)**.

TB 5-25-1 "Instructions for use of Detonator, Concussion Type T1"—Confidential. Describes the construction and operation of the Army version of the **Firing Device, Demolition Mark 6 (14.03)**.

TB 1940-2 "TORPEDO, BANGALORE, M1" Restricted—5 pages. Describes the construction and operation of the **Bangalore Torpedo M1, Kit (33.20)**.

TB 9-1940-6 "CHARGE, DEMOLITION SHAPED 40 LB. T3"—Restricted—3 pages. Describes the construction and operation of **Charge, Shaped, M3 (34.21)**.

IB 143—Restricted—3 pages. Describes the construction and operation of the **Detonator, 15 Second Delay, M1 (16.06)**.

COMMERCIAL PUBLICATIONS

BLASTERS HANDBOOK, DUPONT. A manual describing explosives and practical methods of using them.

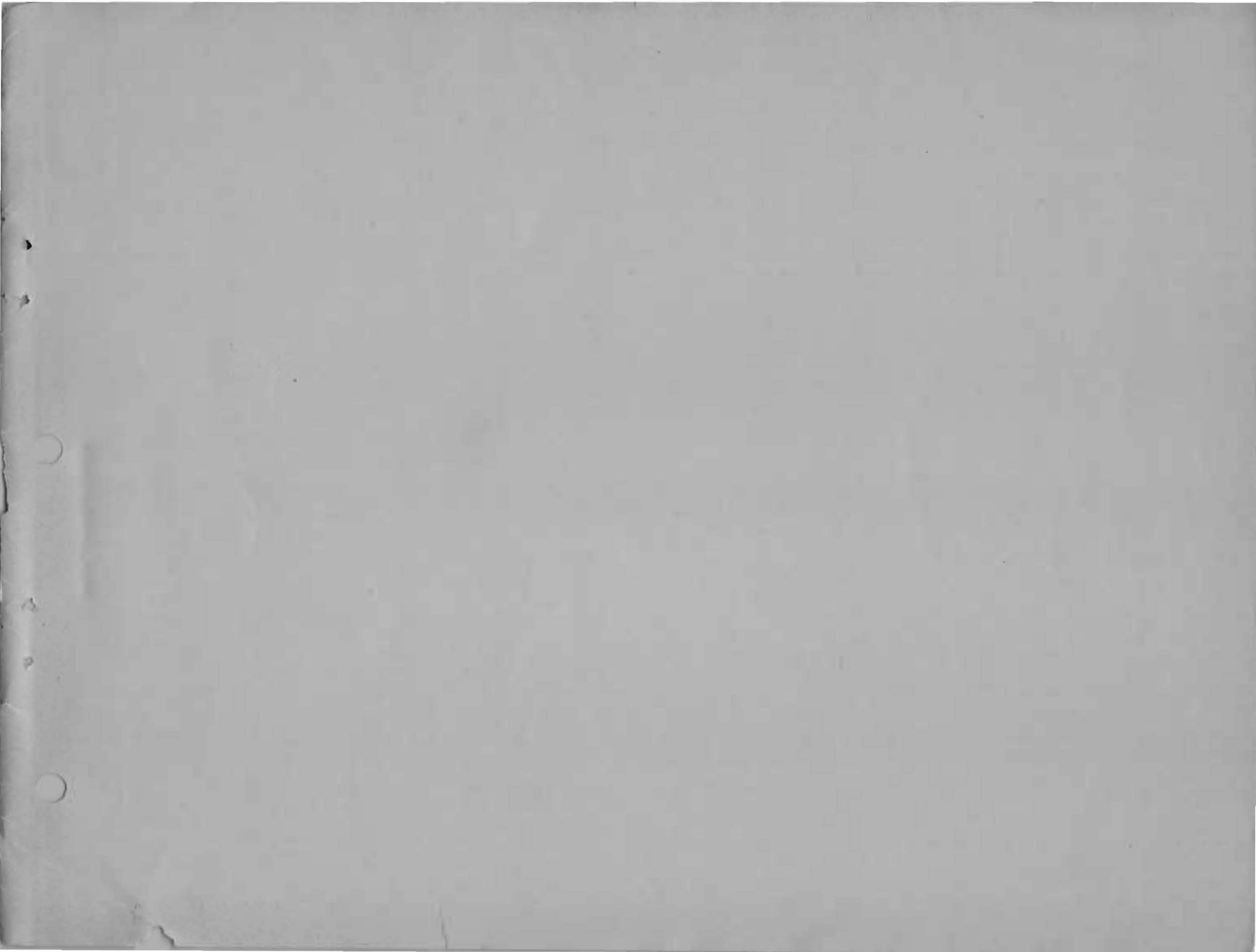

ALPHABETICAL INDEX

APPENDIX V

ADAPTOR, PRIMING	42.40	Caps, Blasting, Identification of	11.00	Combination Firing Device— <i>see</i> Firing Device, Demolition, Mark 1, Mod. 1 ..	14.01
AN-M1—Destructor	39.15	CAP, BLASTING, SPECIAL ELECTRIC	11.02	Composition "C", "C2", or "C3"— <i>see</i> Block, Demolition, M3	31.05
AN-M3—Destructor	39.16	CAP, BLASTING, SPECIAL, NONELECTRIC	11.01	Block, Demolition, M4	31.06
Anti-Personnel Mine M2A1	36.01	Cap Chamber— <i>see</i> Base, Coupling (discussed)	Appendix III	COMPOUND, CAP SEALING	42.20
Anti-Personnel Mine M3	36.02	Cap Crimper M2	42.05	CONTAINER, CAVITY CHARGE, MARK 1, MOD. 0	34.01
Anti-Personnel Mine, Practice, M8	36.08	Cap Crimper, Waterproof	42.04	CONTAINER, CAVITY CHARGE, MARK 3, MOD. 0	34.03
Anti-Tank Mine H.E., M1A1	35.01	Cap, Percussion— <i>see</i> Primer, Percussion Cap	11.10	CORD, DETONATING, PLAIN	17.01
Anti-Tank Mine, Practice, M1B1	35.10	Cap Sealing Compound	42.00	CORD, DETONATING, REINFORCED	17.02
Anti-Tank Mine H.E., M5	35.02	Cavity Charge Container Mark 1, Mod. 0	34.01	CORD, DETONATING, WIREBOUND	17.03
Anti-Tank Mine H.E., Light, M7	35.03	Cavity Charge Container Mark 3, Mod. 0	34.03	Cup Primer— <i>see</i> Primer, Percussion Cap	11.10
Army Firing Wire, Double Cond.	41.02	Carrying Bag— <i>see</i> Haversack	43.20	CUTTER, CABLE AND CHAIN, MARK 1, MOD. 1	34.10
Army Firing Wire Reel	41.10	Chain Cutter— <i>see</i> Cutter, Cable and Chain	34.10	CRIMPER, CAP, M2	42.05
BANGALORE TORPEDO M1, KIT	33.20	Chain Demolition Blocks M1	31.03	CRIMPER, CAP, WATERPROOF	42.04
Base Adaptor— <i>see</i> Base, Coupling (discussed)	Appendix III	Charge Box	43.03	Delay Firing Device M1	16.05
Battery Box—Timer and, Mark 3, Mod. 0 ..	15.10	CHARGE, DEMOLITION, MARK 2, MOD. 0	31.19	Delay Detonator, 15 Second	16.07
Blasting Caps, Identification of	11.00	CHARGE, DEMOLITION, MARK 2, MOD. 1	31.20	Demolition Cable, Single Conductor	41.01
Blasting Cap, Special Electric	11.02	Charge, Demolition, Mark 6, Mod. 0— <i>see</i> Outfit, Demolition, Mark 104, Mod. 1 ..	39.01	Demolition Cable, Double Conductor	41.04
Blasting Cap, Special Nonelectric	11.01	CHARGE, DEMOLITION, MARK 8, MOD. 0	33.01	Demolition Charge— <i>see</i> list this index—Charge, Demolition	Chapter 3
Blasting Machine, Ten Cap	13.01	CHARGE, DEMOLITION, MARK 9, MOD. 0	31.21	Demolition Chest, Platoon	43.01
Blasting Machine, Thirty Cap	13.03	CHARGE, DEMOLITION, MARK 9, MOD. 1	31.22	Demolition Firing Device— <i>see</i> list this index—Firing Device, Demolition ..	Chapter 1
Blasting Galvanometer	42.01	CHARGE, DEMOLITION, MARK 9, MOD. 1	31.22	Demolition Outfit— <i>see</i> list this index—Outfit, Demolition	Chapter 3
Blasting Time Fuse	12.01	CHARGE, DEMOLITION, MARK 14, MOD. 0	31.25	DESTRUCTOR AN-M1	39.15
BLOCKS, DEMOLITION, CHAIN M1	31.03	CHARGE, DEMOLITION, MARK 14, MOD. 1	31.26	DESTRUCTOR AN-M3	39.16
BLOCK, DEMOLITION, M2	31.04	CHARGE, SHAPED, M1	34.19	Detonating Cord, Plain	17.01
BLOCK, DEMOLITION, M3	31.05	CHARGE, SHAPED, M2	34.20	Detonating Cord, Reinforced	17.02
BLOCK, DEMOLITION, M4	31.06	CHARGE, SHAPED, M3	34.21	Detonating Cord, Wirebound	17.03
BLOCK, TNT, 1/2 LB.	31.01	Chemical Delay Pencil— <i>see</i> Firing Device, Delay Type, M1	16.05, 16.01	Detonating Fuze, Hand Grenade M6A4 ..	16.10
BLOCK, TNT, 1 LB.	31.02	CHEST, DEMOLITION, PLATOON ..	43.01	Detonator, Electric, Mark 1, Mod. 1— <i>see</i> Kit, Mine Conversion, Mark 7, Mod. 0 ..	11.15
Booster, Auxiliary, Mark 1, Mod. 0— <i>see</i> Charge, Demolition, Mark 9, Mod. 1 ..	31.22	Circuit Tester— <i>see</i> Galvanometer, Blasting	42.01	Kit, Mine Conversion, Mark 8, Mod. 0 ..	11.16
Booster, Auxiliary, Mark 2, Mod. 0— <i>see</i> Charge, Demolition, Mark 9, Mod. 1 ..	31.22	Clock Delay Firing Device— <i>see</i> Firing Device, Demolition, Mark 3 Mod 0 ..	16.10	DETONATOR, 15 SECOND DELAY, M1	16.07
Booster Mark 8, Mod. 0— <i>see</i> Charge, Demolition, Mark 8, Mod. 0	33.01	Concussion Firing Device or Concussion Detonator— <i>see</i> Firing Device, Demolition Mark 6, Mod. 0 with Arming Cell Mark 1 and Mods	14.02-14.06	Detonator Holder Mark 2, Mod. 0— <i>see</i> Kit, Mine Conversion Mark 7, Mod. 0 ..	11.15
Booster Mark 12, Mod. 0— <i>see</i> Charge, Demolition, Mark 8, Mod. 0	33.01	Controlled Mine Mark 20, Mod. 0— <i>see</i> Kit, Mine Conversion, Mark 7, Mod. 0 ..	11.15	Kit, Mine Conversion Mark 8, Mod. 0 ..	11.16
BOOSTER MARK 13, Mod. 0	22.05	Controlled Mine Mark 37, Mod. 0— <i>see</i> Kit, Mine Conversion, Mark 8, Mod. 0 ..	11.16	Electric Cap Box	43.10
Bouchon Fuze— <i>see</i> Fuze, Detonating, Hand Grenade, M6A4	16.10			Electric Detonator Mark 1, Mod. 1— <i>see</i> Kit, Mine Conversion Mark 7, Mod. 0 ..	11.15
BOX, CHARGE	43.03			Kit, Mine Conversion Mark 8, Mod. 0 ..	11.16
BOX, ELECTRIC CAP	43.10			Engineer's Special Electric Cap— <i>see</i> Cap, Blasting, Special Electric	11.02
BOX, NONELECTRIC CAP	43.11			Engineer's Special Nonelectric Cap— <i>see</i> Cap, Blasting, Special Nonelectric ..	11.01
Box, Reel, Mark 2, Mod. 0	41.15				
Burning Charge, Thermit, Mark 1, Mod. 0	38.02				
Cable and Chain Cutter Mark 1, Mod. 1 ..	34.10				
CABLE, DEMOLITION, SINGLE CONDUCTOR	41.01				
CABLE, DEMOLITION, DOUBLE CONDUCTOR	41.04				

RESTRICTED

109

ALPHABETICAL INDEX

APPENDIX V

Explosive Hose— <i>see</i> Charge, Demolition, Mark 8, Mod. 0	33.01	Holder, Detonator, Mark 2, Mod. 0— <i>see</i> Kit, Mine Conversion, Mark 7, Mod. 0	11.15	M48 Trip Flare	36.10
Fifteen Second Delay Detonator M1	16.07	Kit, Mine Conversion, Mark 8, Mod. 0	11.16	M49 Trip Flare	36.11
FIRING DEVICE, DELAY TYPE, M1	16.05	Hose, Explosive— <i>see</i> Charge, Demolition, Mark 8, Mod. 0	33.01	Mark 1, Mod. 0 Auxiliary Booster— <i>see</i> Charge, Demolition, Mark 9, Mod. 1	31.22
FIRING DEVICE, DEMOLITION, MARK 1, MOD. 1	14.01	IDENTIFICATION OF BLASTING		Mark 1, Mod. 1 Cable and Chain Cutter	34.10
FIRING DEVICE, DEMOLITION, MARK 3, MOD. 0	16.01	CAPS	11.00	Mark 1 Cavity Charge Container	34.01
FIRING DEVICE, DEMOLITION, MARK 6, WITH ARMING CELL, MARK 1 AND MODS	14.02, 14.06	Initiator Block— <i>see</i> Charge, Demolition, Mark 9 and Mods	31.21, 31.22	Mark 1, Mod. 1 Demolition Firing Device	14.01
FIRING DEVICE, PRESSURE TYPE, M1	14.15	Igniter, Thermit, Mark 1, Mod. 0	38.01	Mark 1, Mod. 1 Electric Detonator— <i>see</i> Kit, Mine Conversion, Mark 7, Mod. 0	11.15
FIRING DEVICE, PULL FRICTION, M2	14.19	KIT, MINE CONVERSION, MARK 7, MOD. 0	11.15	Kit, Mine Conversion, Mark 8, Mod. 0	11.16
FIRING DEVICE, PULL TYPE, M1	14.16	KIT, MINE CONVERSION, MARK 8, MOD. 0	11.16	Mark 1, Mod. 0 Thermit Burning Charge	38.02
FIRING DEVICE, PULL RELEASE TYPE, M3	14.18	Light Antitank Mine H.E., M7	35.03	Mark 1, Mod. 0 Thermit Igniter	38.01
FIRING DEVICE, RELEASE TYPE, M1	14.17	LIGHTER, FUSE, FRICTION TYPE, M1	14.30	Mark 2, Mod. 0 Auxiliary Booster— <i>see</i> Charge, Demolition, Mark 9, Mod. 1	31.22
Firing Wire, Double Cond. Army	41.02	LIGHTER, FUSE, WEATHERPROOF M2	14.31	Mark 2, Mod. 0 Demolition Charge	31.19
Firing Wire, Double Cond. Army Light Weight	41.03	Lightweight Firing Wire, 2 Cond.	41.03, 41.05	Mark 2, Mod. 1 Demolition Charge	31.20
Firing Wire, Double Conductor, Navy, Light Weight	41.05	M1A1 H.E. Antitank Mine	35.01	Mark 2, Mod. 1 Detonator Holder— <i>see</i> Kit, Mine Conversion, Mark 7, Mod. 0	11.15
Firing Wire Reel, Army	41.10	M1(AN) Destructor	39.15	Kit, Mine Conversion, Mark 8, Mod. 0	11.16
Firing Wire Reel, RL39A	41.11	M1 Pangalore Torpedo Kit	33.20	Mark 2, Mod. 0 Reel Box	41.15
FLAPE, TRIP, M48	36.10	M1 Chain Demolition Blocks	31.03	Mark 2, Mod. 1 Underwater Thermit Charge	38.04
FLARE, TRIP, M49	36.11	M1 Delay Firing Device	16.05	Mark 3, Mod. 0 Cavity Charge Container	34.03
Four Way Firing Device— <i>see</i> Firing Device, Demolition, Mark 1, Mod. 1	14.01	M1—15 Second Delay Detonator	16.07	Mark 3, Mod. 0 Demolition Firing Device	16.01
Friction Type Fuse Lighter M1	14.30	M1B1—Practice Antitank Mine	35.10	Mark 3, Mod. 0 Timer and Battery Box	15.10
FUSE, BLASTING, TIME	12.01	M1A1—Pressure Type Firing Device	14.15	Mark 6, Mod. 0 Demolition Charge— <i>see</i> Outfit, Demolition, Mark 104	39.01
Fuse Lighter, Friction Type M1	14.30	M1 Pull Type Firing Device	14.16	Mark 6, Mod. 0 Demolition Firing Device with Arming Cell Mark 1 and Mods.	14.02, 14.06
Fuse Lighter, Weatherproof M2	14.31	M1 Friction Type Fuse Lighter	14.30	Mark 7, Mod. 0 Mine Conversion Kit	11.15
FUZE, MARK 143, MOD. 0	21.01	M1 Release Firing Device	14.17	Mark 8, Mod. 0 Booster— <i>see</i> Charge, Demolition, Mark 8 Mod 0	33.01
FUZE, MARK 143, MOD. 1	21.02	M1 Shaped Charge	34.19	Mark 8, Mod. 0 Demolition Charge	33.01
FUZE, DETONATING, HAND GRENADE, M6A4	16.10	M2A1 Antipersonnel Mine	36.01	Mark 8, Mod. 0 Mine Conversion Kit	11.16
GALVANOMETER, BLASTING	42.01	M2 Cap Crimper	42.05	Mark 9, Mod. 0 Demolition Charge	31.21
GRENADE, HAND, OFFENSIVE, MARK III A2	36.20	M2 Demolition Block	31.04	Mark 9, Mod. 1 Demolition Charge	31.22
Hand Grenade Detonating Fuze M6A4	16.10	M2 Pull Friction, Firing Device	14.19	Mark 12, Mod. 0 Booster— <i>see</i> Charge, Demolition Mark 8, Mod. 0	33.01
Hand Grenade, Offensive, Mark III A2	36.20	M2 Shaped Charge	34.20	Mark 13, Mod. 0 Booster	22.05
HAVERSACK	43.20	M2 Weatherproof Fuse Lighter	14.31	Mark 14, Mod. 0 Demolition Charge	31.25
Hell Box— <i>see</i> Machine, Blasting	13.01	M3 Antipersonnel Mine	36.02	Mark 14, Mod. 1 Demolition Charge	31.26
Machine, Blasting	13.01	M3 Demolition Block	31.05	Mark 20, Mod. 0 Controlled Mine— <i>see</i> Kit, Mine Conversion, Mark 7, Mod. 0	11.15
Machine, Blasting	13.03	M3(AN) Destructor	39.16	Mark 37, Mod. 0 Controlled Mine— <i>see</i> Kit, Mine Conversion, Mark 8, Mod. 0	11.16
		M3 Pull Release Firing Device	14.18	Mark 104, Mod. 1 Demolition Outfit	39.01
		M3 Shaped Charge	34.21	Mark 108, Mod. 0 Demolition Outfit	39.02
		M4 Demolition Block	31.06	Mark 143 and Mods Fuze	21.01, 21.02
		M5 H.E. Antitank Mine	35.02		
		M6A3—Hand Grenade Detonating Fuze	16.10		
		M7, H.E., Light Antitank Mine	35.03		
		M8 Practice Antipersonnel Mine	36.08		

ALPHABETICAL INDEX

APPENDIX V

MACHINE, BLASTING, TEN CAP ...	13.01	Platoon Demolition Outfit	43.01	Tetrytol Block— <i>see</i>	
MACHINE, BLASTING, THIRTY CAP	13.03	Practice Antipersonnel Mine M8	36.08	Block, Demolition, M2	31.04
MINE, ANTIPERSONNEL, M2A1	36.01	Practice Antitank Mine M1B1	35.10	THERMIT BURNING CHARGE MARK	
MINE, ANTIPERSONNEL, M3	36.02	Pressed TNT—Block— $\frac{1}{2}$ LB.	31.01	1, MOD. 0	38.02
MINE, ANTIPERSONNEL, PRAC-		Pressed TNT—Block—1 LB.	31.02	THERMIT CHARGE, UNDERWATER,	
TICE, M8	36.08	Pressure Firing Device M1	14.15	MARK 2, MOD. 1	38.04
MINE, ANTITANK, H.E., M1A1	35.01	Primacord, Plain— <i>see</i> Cord, Detonating,		THERMIT IGNITER MARK 1,	
MINE, ANTITANK, PRACTICE		Plain	17.01	MOD. 0	38.01
M1B1	35.10	Primacord, Reinforced— <i>see</i> Cord, Detonating,		THERMIT UNIT, 10 LB.	38.10
MINE, ANTITANK, H.E., M5	35.02	Reinforced	17.02	Time Fuse	12.01
MINE, ANTITANK, H.E. LIGHT,		Primacord, Wirebound— <i>see</i> Cord, Detonating,		TIMER AND BATTERY BOX MARK	
M7	35.03	Wirebound	17.03	3, MOD. 0	15.10
Mine Conversion Kit Mark 7, Mod. 0 ..	11.15	PRIMER, PERCUSSION CAP	11.10	TNT Block, $\frac{1}{2}$ Lb.	31.01
Mine Conversion Kit Mark 8, Mod. 0 ..	11.16	Primer Coupler	Appendix III	TNT Block, 1 Lb.	31.02
Navy Cap Chamber—part of Booster		Priming Adaptor	42.40	Torpedo, Bangalore, M1, Kit	33.20
Mark 13, Mod. 0	22.05	Pull Friction Firing Device M2	14.19	Trip Flare M48	36.10
Nonelectric Cap Box	43.11	Pull Release Firing Device M3	14.18	Trip Flare M49	36.11
Non-Metallic or Non-Detectable Land		Pull Type Firing Device M1	14.16	Underwater Thermit Charge Mark 2,	
Mine— <i>see</i> Mine, Antitank, M5	35.02	Pull Wire Fuse Lighter— <i>see</i>		Mod. 1	38.04
Offensive Hand Grenade Mark III A2 ..	36.20	Lighter, Fuse, Friction Type, M1 ...	14.30	Unit, Thermit, 10 Lb.	38.10
Ohmmeter—issued only as part of—		REEL, ARMY FIRING WIRE	41.10	Waterproof Cap Crimper	42.04
Reel Box Mark 2, Mod. 0	41.15	REEL, WIRE, FIRING, RL39A	41.11	Waterproofing Compound— <i>see</i>	
For equivalent for separate issue,		REEL BOX MARK 2, MOD. 0	41.15	Compound, Cap Sealing	42.20
<i>see</i> Galvanometer, Blasting	42.01	Reinforced Detonating Cord	17.02	Weatherproof Fuse Lighter M2	14.31
OUTFIT, DEMOLITION, MARK 104,		Release Firing Device M1	14.17	Western No. 3 Battery Cup Primer— <i>see</i>	
MOD. 1	39.01	Safety Fuse— <i>see</i>		Primer No. 3 Cup	11.10
OUTFIT, DEMOLITION, MARK 108,		Fuse, Blasting, Time	12.01	Wirebound Detonating Cord	17.03
MOD. 0	39.02	Shaped Charge M1	34.19	WIRE, FIRING, DOUBLE COND.	
Percussion Cap— <i>see</i> Primer, Percussion		Shaped Charge M2	34.20	ARMY	42.02
Cap	11.10	Shaped Charge M3	34.21	WIRE, FIRING DOUBLE COND.	
Percussion Type Fuse Lighter— <i>see</i>		Special Electric Blasting Cap	11.02	ARMY LIGHTWEIGHT	41.03
Lighter, Fuse, Weatherproof, M2 ...	14.31	Special Nonelectric Blasting Cap	11.01	Wire, Firing, Heavy Duty— <i>see</i>	
Plain Detonating Cord	17.01	Tester Circuit— <i>see</i>		Cable, Demolition, Double Conductor,	
Plastic Explosive— <i>see</i>		Galvanometer, Blasting	42.01	NAVY LIGHTWEIGHT	41.04
Block, Demolition, M3	31.05	Tetrytol Paek or Chain— <i>see</i>		Zero Hour Clock Firing Device— <i>see</i>	
Block, Demolition, M4	31.06	Blocks, Demolition, Chain M1	31.03	Firing Device, Demolition Mark 3,	
				Mod. 0	16.01

DISTRIBUTION

Requests for additional copies of OP 1178 should be submitted on NAVORD FORM 1, ORDNANCE PUBLICATIONS AND FORMS REQUISITION, to the nearest Ordnance Publications, Distribution Center: Navy Yard, Wash. 25, D. C.; Adak, Alaska; Mare Island, Calif.; Espiritu Santo, New Hebrides; Exeter, England; Pearl Harbor, T. H.; Manus Island, Admiralty Islands. Distribution Center mailing addresses should be obtained from List 10 nn of the Standard Navy Distribution List, or from the reverse side of NAVORD FORM 1.

DISTRIBUTION :

Standard Navy Distribution List No. 28

2 copies unless otherwise noted:

1. a, d, e, g-l; 2. k, m (1), n, r; 3. c (1), j-l, o, p, r, x, y, aa, jj, kk, nn, ww; B3. CONSTRUCTION BATTALIONS; 4. c (1), j-l, o, p, r, r (1), x, y, aa, jj, kk, nn, ww; 5. b; 6. a; 7. e, f, h, r, x, dd*; 7. (5 copies), b, c, j, p, s; 8. h*, i, j, n (SPECIAL LIST K, N, P, V, Z, AA); 10. qq, ss; 10. (25 copies), nn; 11. a (BuDocks, ComdtMarCorps); 12. a, b (Revision 1); 13. a, c-f, i, r, aa, cc, hh*, nn; 14. a, q.

* Applicable Addressees.